



# High Power Amplifier

## Model:RPA-26G5-40G-200

26.5-40GHz 200W CW

Ultrabroad frequency range, high performance and exceptional RF characteristics

### Features:

- Frequency range: 26.5-40GHz
- High output power at saturation, 53dBm Min.
- High gain, 53dB Min.
- Operates from AC line power: 380V

### Applications:

- Laboratory test instrument
- RF Power stress test
- EMI and antenna testing
- Reliability testing

### Product Overview:

The RPA-26G5-40G-200 is a high power, rack mount amplifier with a self-contained AC power supply which can be used for a wide variety of laboratory testing applications. This rugged amplifier is capable of amplifying signals up to 200W output power over its entire operating bandwidth of 26.5 to 40GHz. The control functions that RPA-26G5-40G-200 possesses include the on/off of the power supply and output power can be controlled by the automatic ALC system. Built-in safety features include fans alarms and automatic shut down mechanism to prevent damage in the event of excessive internal temperatures. The amplifier's output stage is further protected in the event of a fault condition, allowing high power operation for up to 5 minutes into an open or short load (refer to the maximum input power specifications). And it has built-in protection functions included over TEM, over voltage, over current and over VSWR protection. It can also be remotely controlled via RS422, LAN, GPIB or USB.



## Electrical Specifications at 25°C:

Parameter	Symbol	Min	Typ	Max	Units
Frequency range	BW	26.5-40			GHz
Power Gain	GP	53			dB
Gain flatness	$\Delta$ GL		$\pm 5$		dB
Output Psat	Psat	53			dBm
Spurious@Pout=53dBm	Spur			-50	dBc
Harmonics@Pout=53dBm	HAM			-20	dBc
Input VSWR	VSWRin			2.0	:1
AC Voltage	Vac		380		V AC
Power Consumption	Pdiss			5000	W
Impedance	I/O-IMP	50			Ohms

## Mechanical Specifications:

Parameter	Value	Notes
Operating Temperature*	-20 to +40	°C
Non-operating Temperature*	-30 to +50	°C
Relative humidity	95	%
RF Input/Output Connector	2.92 Female/WR28	
Forward/Reverse Coupling	2.92mm Female/ 2.92mm Female	
Communication Interfaces	RJ45/DB9	
Digital Monitor & Control	Serial:RS422;LAN;GPIB;USB	Optional: GPIB
Cooling	Built in Cooling system,forced air cooling	
Altitude	10,000	feet
Shock / Vibration(MIL-STD-810F)	25g rms (15 degree 2KHz) endurance, 1 hour per axis	
Shock(non operating)	20G for 11msc half sin wave,3 axis both directions	
Front Panel LCD Screen Display	7 inch LCD Screen Display	
Dimensions W x H x D	12U	mm
Weight	$\leq 150$	Kg

\*Note: For a wider temperature range, please consult the manufacturer.



## Absolute Maximum Ratings:

Parameter	Value
RF Input Power	+5 dBm
ESD sensitivity (HBm)	Class 0, passed 150V

## Outline Drawing:

Unit:mm

RPA-26G5-40G-200

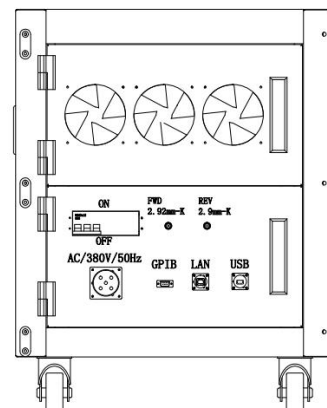
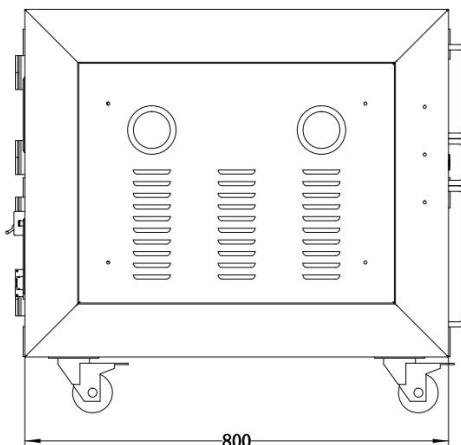
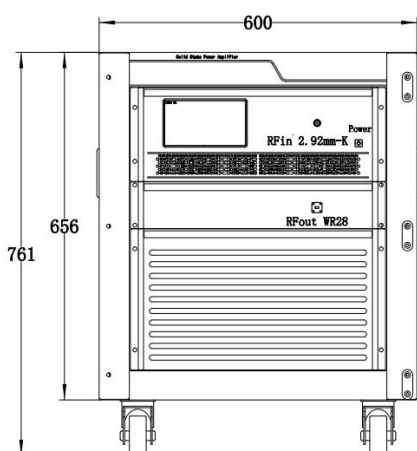

## Optional items:

Number	Parameter
1	LCD display touchscreen
2	Ingress protection grad
3	Customized operating temperature range
4	Built in Cooling system(air or liquid)
5	Types of RF,coupling and monitor&control interfaces



## Outline Drawing:

Base Number	Description	Optional
RPA-26G5-40G-200	High Power Amplifier, 26.5-40GHz, 200W CW, Built in air or liquid cooling, without LCD and IP grad.	Basic version
RPA-26G5-40G-200-M	High Power Amplifier, 26.5-40GHz, 200W CW, Built in air or liquid cooling, with LCD.	Add LCD display touchscreen
RPA-26G5-40G-200-IPxx	High Power Amplifier, 26.5-40GHz, 200W CW, Built in air or liquid cooling, with LCD and IP grad.	Add Ingress protection grad

## Typical Performance Data:

Small Signal Gain vs Frequency

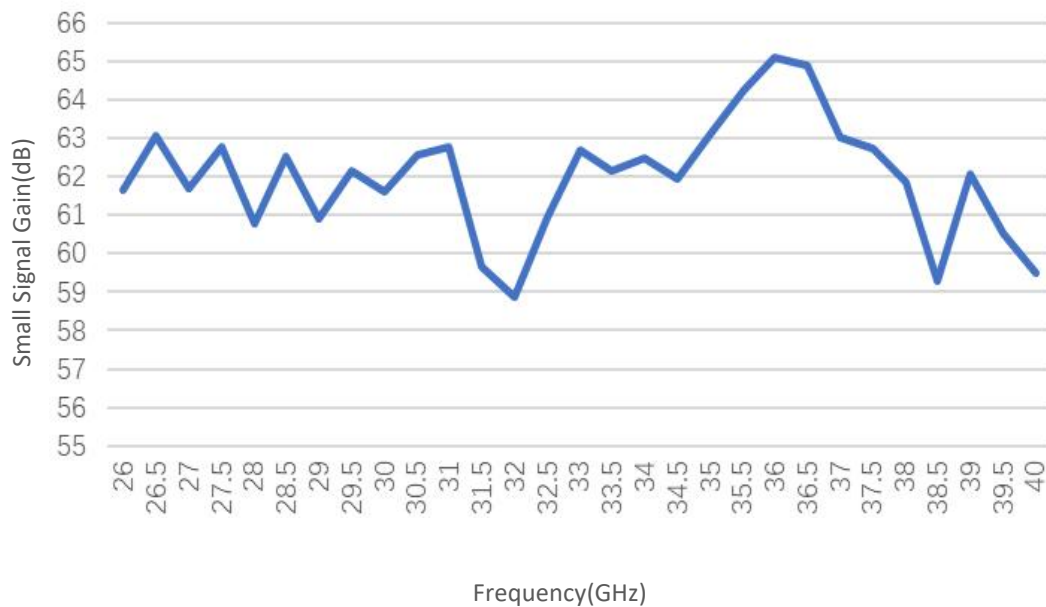

Note: Above data is for ref only, actual data may vary from unit to unit depending on operating environment and other factors like material lots etc.



## Typical Performance Data:

### Input VSWR vs Frequency

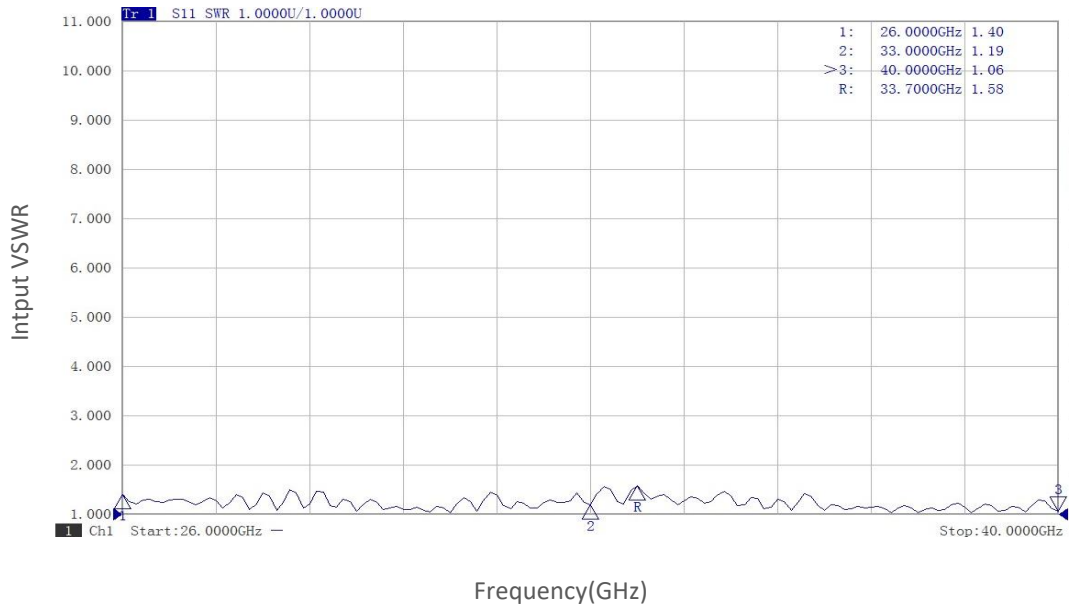

### Output VSWR vs Frequency

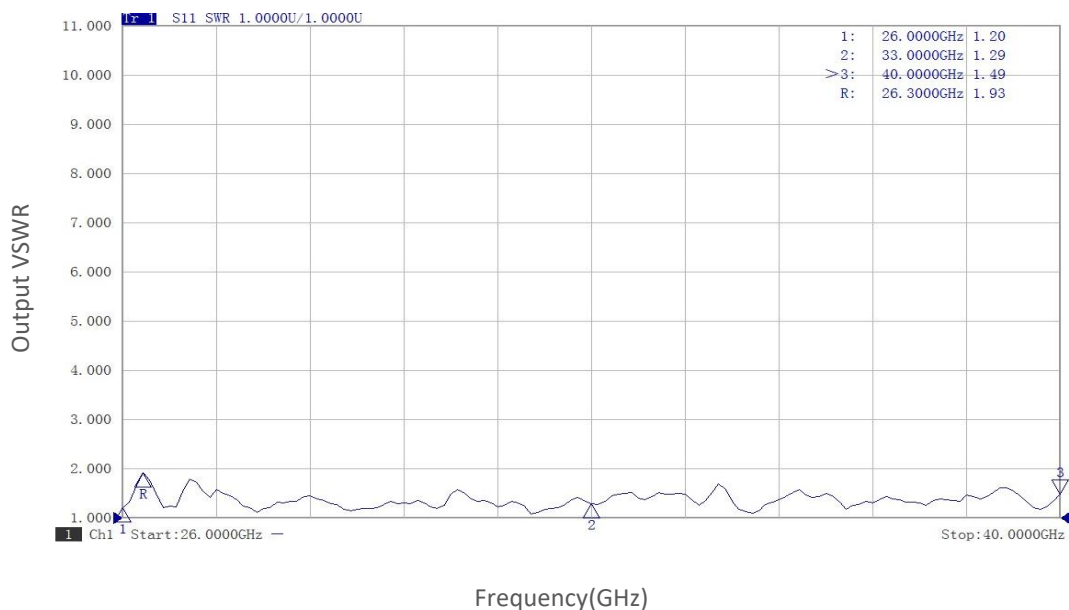

Note: Above data is for ref only, actual data may vary from unit to unit depending on operating environment and other factors like material lots etc.



## Typical Performance Data:

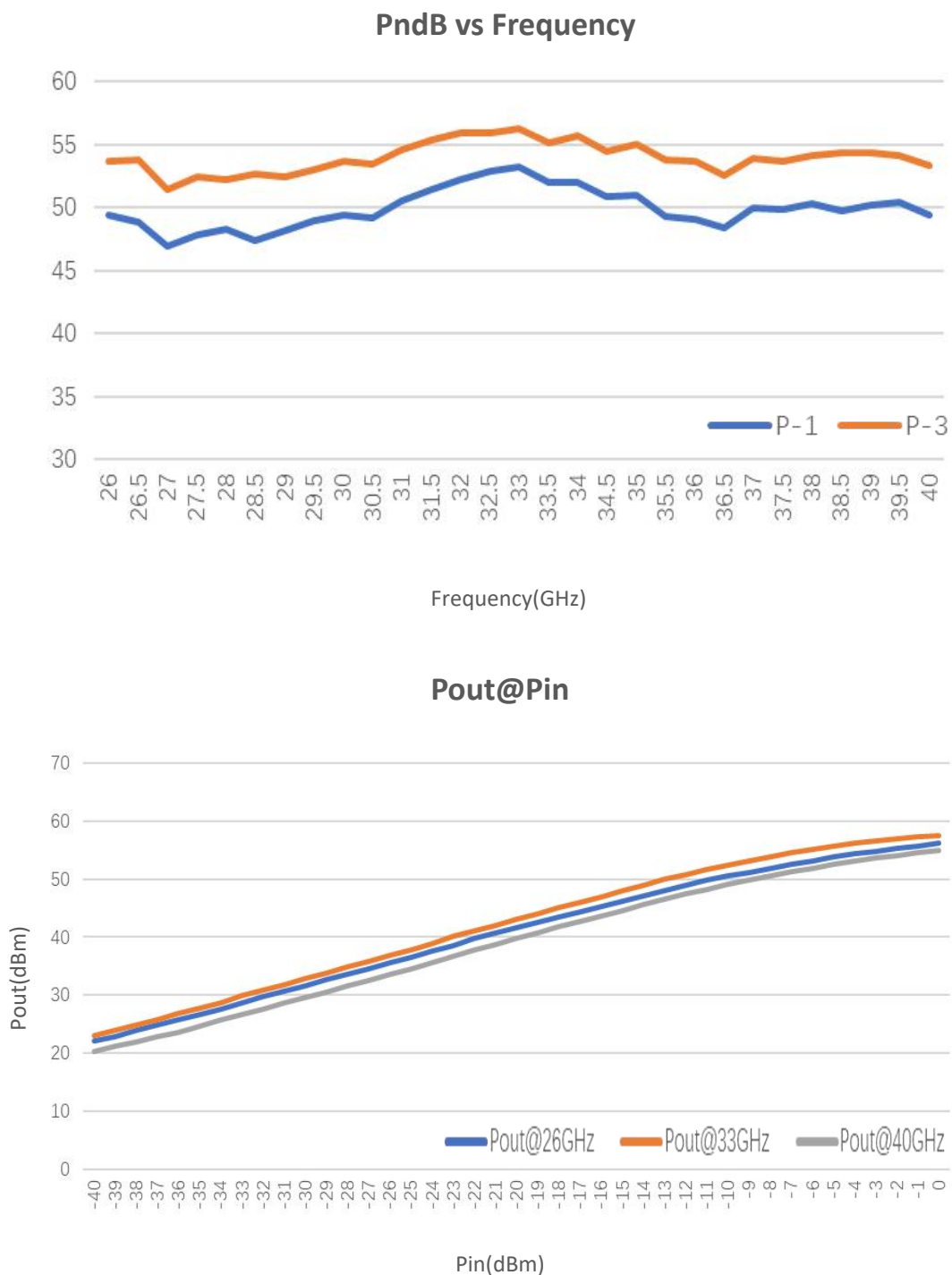

Note: Above data is for ref only, actual data may vary from unit to unit depending on operating environment and other factors like material lots etc.



## Typical Performance Data:

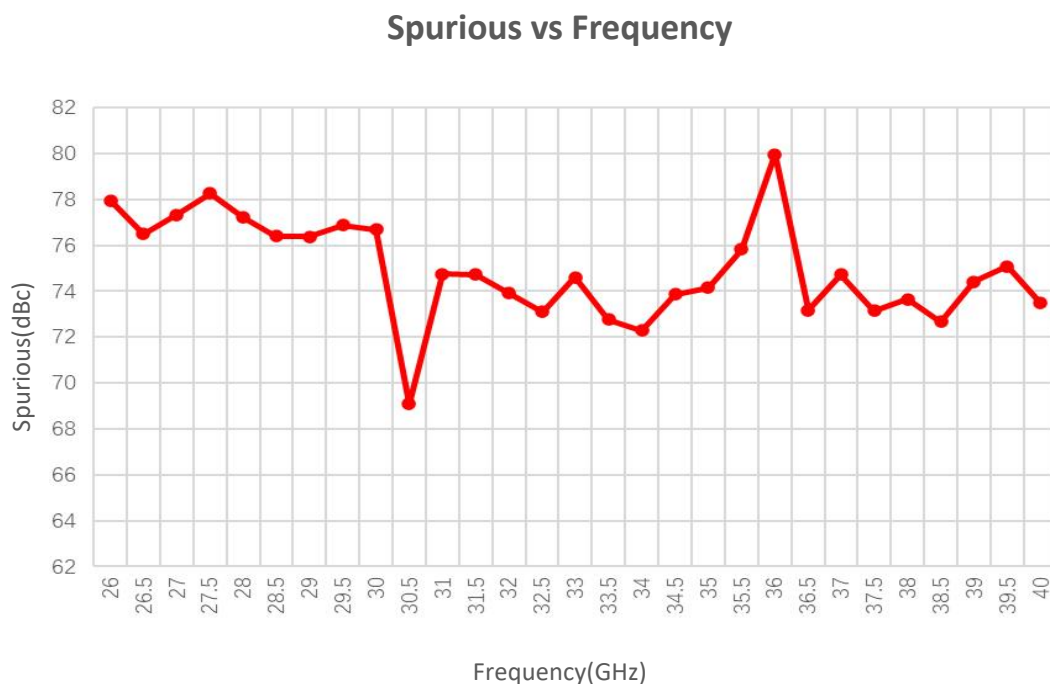
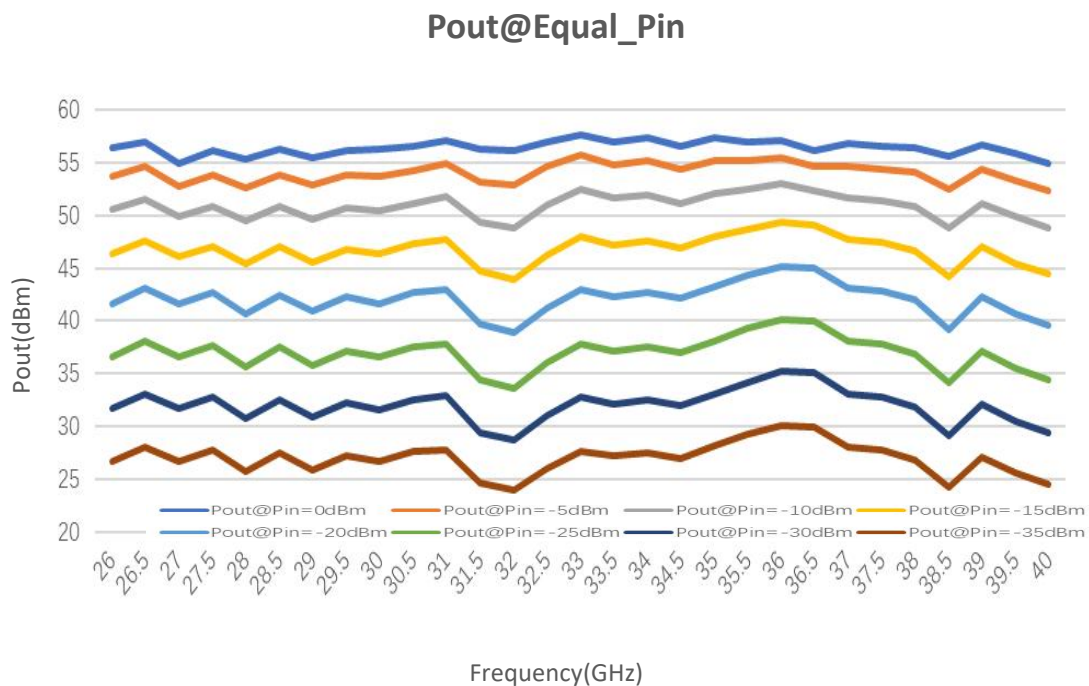

Note: Above data is for ref only, actual data may vary from unit to unit depending on operating environment and other factors like material lots etc.