



# Power Amplifier

## Model: PA-1G-6G-20

1-6GHz 20W CW

Ultrabroad frequency range, high performance and exceptional RF characteristics

### Features:

- Frequency range: 1-6GHz
- High output power at saturation, 20W Min.
- High gain, 43 dB Min.
- 50 Ohm Matched Input / Output.

### Applications:

- Cellular
- PCN
- GSM
- ISM
- Lab Test

### Product Overview:

The PA-1G-6G-20 is a power amplifier with a minimum power gain of 43 dB and a minimum Psat of 20W across the frequency range of 1 to 6GHz. The DC power requirement for the amplifier is +36 VDC/3 A. The input and output port configuration offers coax adapter structure with SMA female.



## Electrical Specifications at 25°C:

Parameter	Min	Typ	Max	Units
Frequency range	1		6	GHz
Power Gain	43			dB
Power Gain Flatness		±3.5		dB
Output P1dB		37		dBm
Output Psat	43			dBm
Spurious@Pout=43dBm			-50	dBc
Input VSWR		1.5	2.5	:1
DC Voltage		+36		V DC
DC Supply Current		3		A
Impedance		50		Ohms

## Mechanical Specifications:

ParameterKg	Value	Notes
Operating Temperature*	-40°C to +50°C	
Non-operating Temperature*	-50°C to +60°C	
Relative humidity	95%	
RF Input/Output Connector	SMA Female/SMA Female	
DC Bias	Feedthru capacitors	
Altitude	10,000	feet
Shock / Vibration(MIL-STD-810F)	25g rms (15 degree 2KHz) endurance, 1 hour per axis	
Shock(non operating)	20G for 11msc half sin wave,3 axis both directions	
Dimensions W x H x D	60*60*11(Without heatsink) 188*125*146(With heatsink)	mm
Weight	≤200	g

\*Note: For a wider temperature range, please consult the manufacturer.

## Absolute Maximum Ratings:

Parameter	Value
Supply Bias Voltage	+39 V
RF Input Power	+5 dBm
ESD sensitivity (HBm)	Class 0, passed 150V



## Outline Drawing:

Unit:mm

PA-1G-6G-20-HS

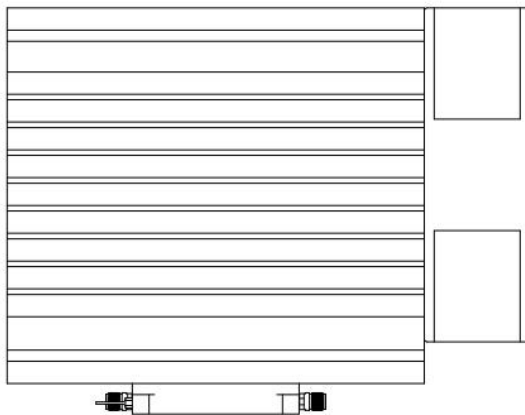
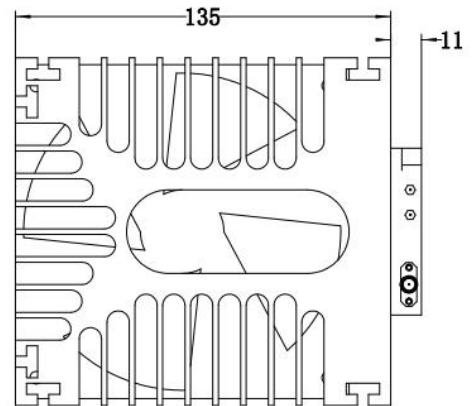
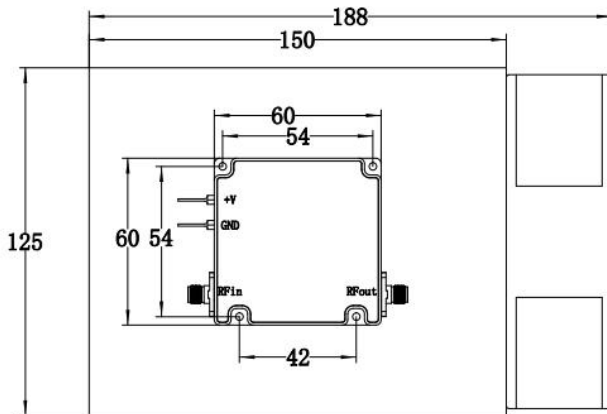

## Ordering Information:

Base Number	Description	Optional
PA-1G-6G-20	Power Amplifier,1-6GHz, Gain:43dB,Psat:20W,+36V DC	Without Heatsink
PA-1G-6G-20-HS	Power Amplifier,1-6GHz, Gain:43dB,Psat:20W,+36V DC	With Heatsink



## Typical Performance Data:

### Input VSWR vs Frequency

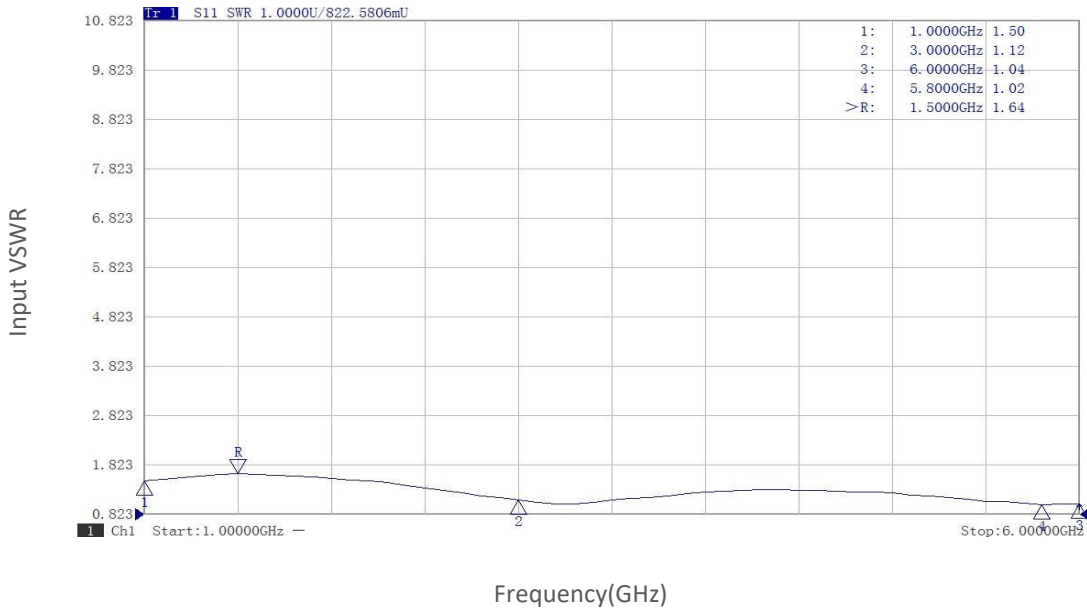

### Small Signal Gain vs Frequency

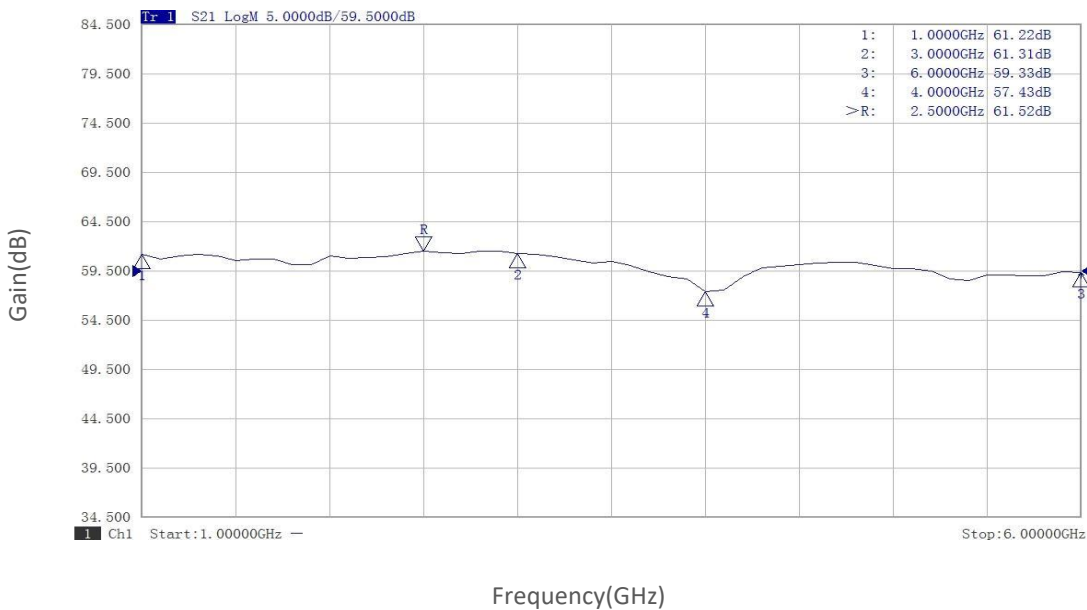

Note: Above data is for ref only, actual data may vary from unit to unit depending on operating environment and other factors like material lots etc.



## Typical Performance Data:

### P1dB vs Frequency

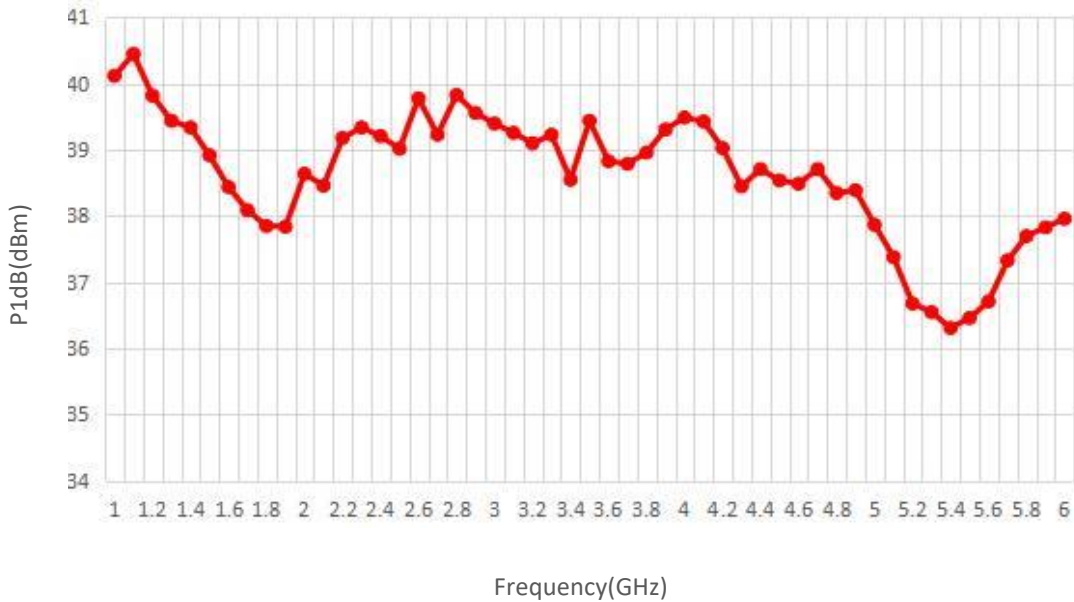

### Pout@Pin

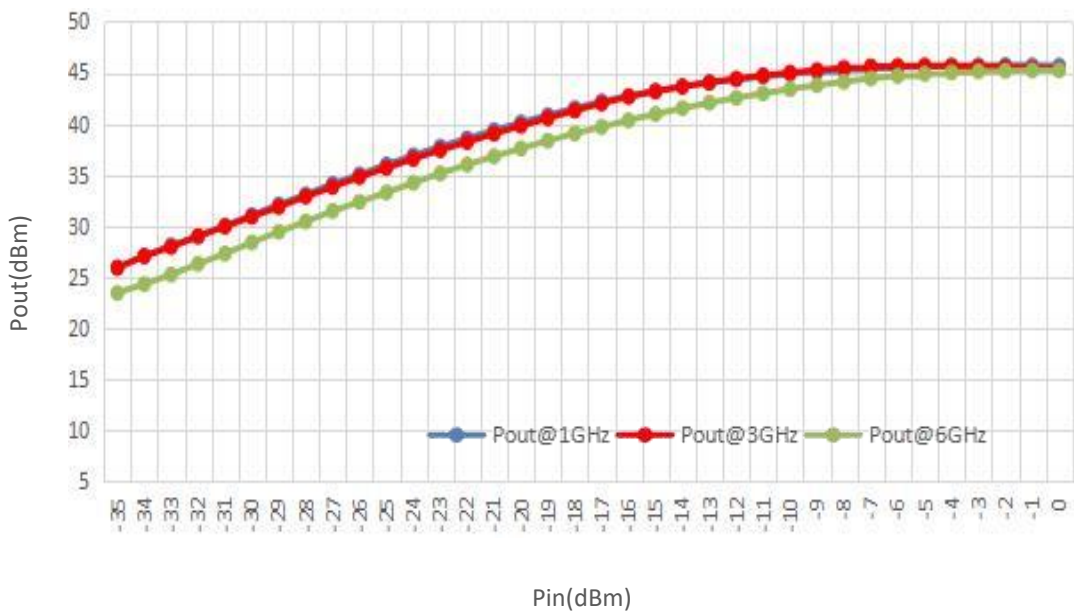

Note: Above data is for ref only, actual data may vary from unit to unit depending on operating environment and other factors like material lots etc.



## Typical Performance Data:

### Pout@Equal\_Pin

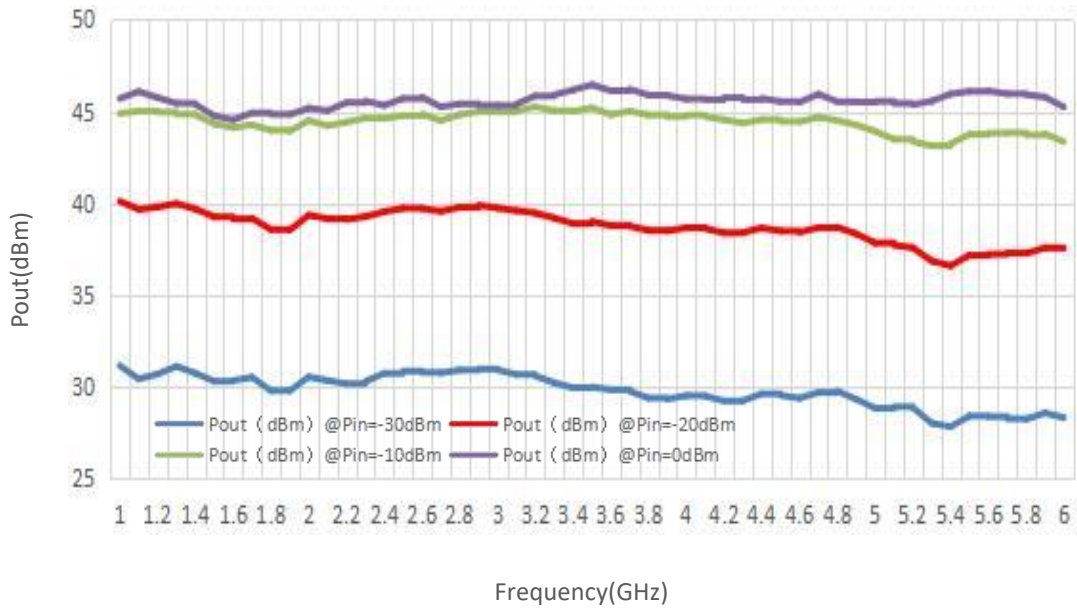

### Spurious vs Frequency

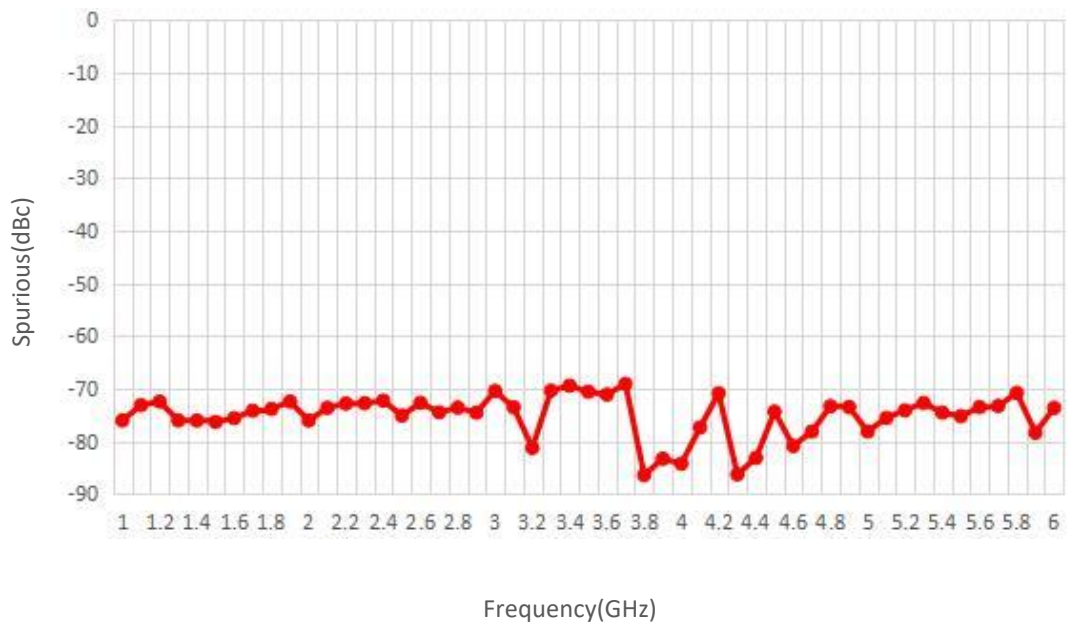

Note: Above data is for ref only, actual data may vary from unit to unit depending on operating environment and other factors like material lots etc.



## Typical Performance Data:

### Harmonic vs Frequency

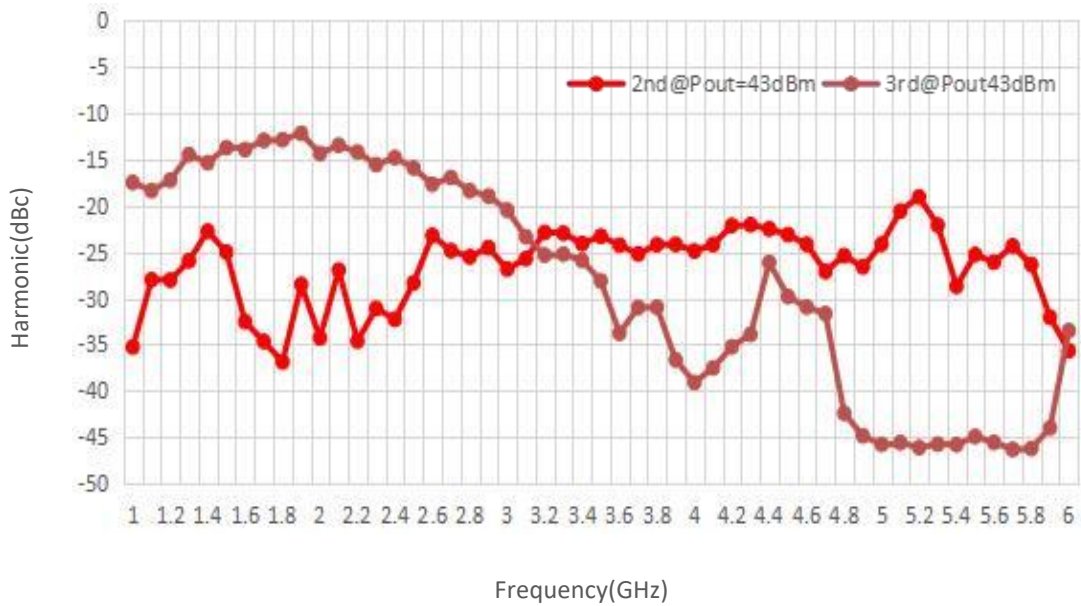

Note: Above data is for ref only, actual data may vary from unit to unit depending on operating environment and other factors like material lots etc.