



Power Amplifier

Model: PA-18G-40G-1.2

18-40GHz 1.2W CW

Ultrabroad frequency range, high performance and exceptional RF characteristics

Features:

- Frequency range: 18-40GHz
- High output power at saturation, 1.2W Typ.
- High gain, 35 dB Min.
- 50 Ohm Matched Input / Output.

Applications:

- Cellular
- PCN
- GSM
- ISM
- Lab Test

Product Overview:

The PA-18G-40G-1.2 is a power amplifier with a minimum small signal gain of 35 dB and a nominal P_{sat} of 1.2W across the frequency range of 18 to 40GHz. The DC power requirement for the amplifier is +12 VDC/2.2 A. The input and output port configuration offers coax adapter structure with 2.92mm female.



Electrical Specifications at 25°C:

Parameter	Min	Typ	Max	Units
Frequency range	18		40	GHz
Small Signal Gain	35	40		dB
Small Signal Gain Flatness		±3		dB
Output P1dB	27	29		dBm
Output Psat		31		dBm
Input VSWR		2		:1
Output VSWR		2		:1
DC Voltage		+12		V DC
DC Supply Current		2.2		A
Impedance		50		Ohms

Mechanical Specifications:

Parameter	Value	Notes
Operating Temperature*	-40°C to +60°C	
Non-operating Temperature*	-50°C to +70°C	
Relative humidity	95%	
RF Input/Output Connector	2.92mm Female/2.92mm Female	
DC Bias	Solder Pin	
Altitude	10,000	feet
Shock / Vibration(MIL-STD-810F)	25g rms (15 degree 2KHz) endurance, 1 hour per axis	
Shock(non operating)	20G for 11msc half sin wave,3 axis both directions	
Dimensions W x H x D	60*50*12	mm

*Note: For a wider temperature range, please consult the manufacturer.

Absolute Maximum Ratings:

Parameter	Value
Supply Bias Voltage	TBD
RF Input Power	+3 dBm
ESD sensitivity (HBm)	Class 0, passed 150V



Outline Drawing:

Unit:mm

PA-18G-40G-1.2

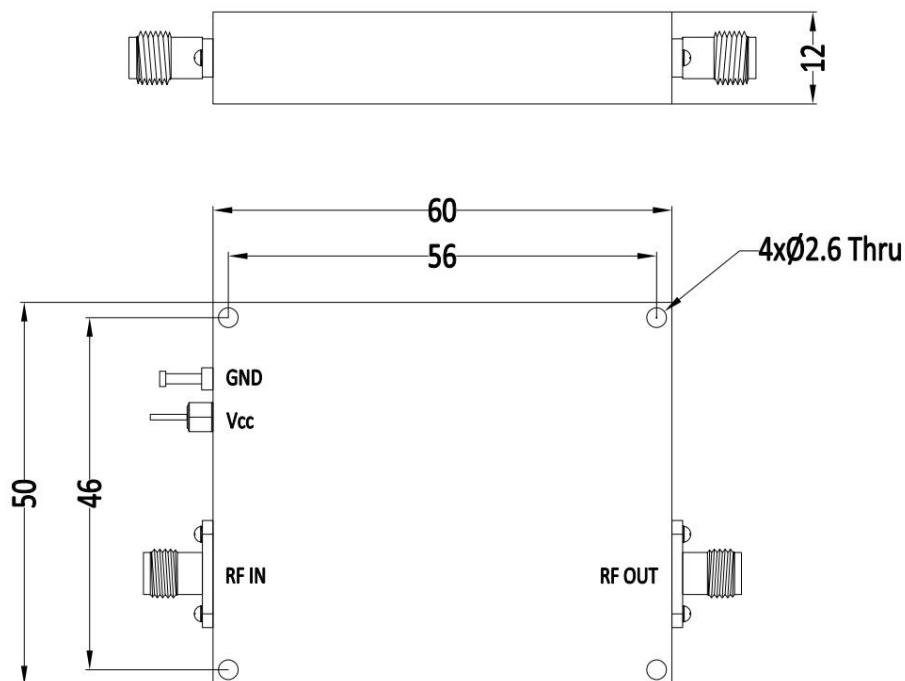

Ordering Information:

Base Number	Description	Optional
PA-18G-40G-1.2	Power Amplifier,18-40GHz, Gain:35dB,Psat:1.2W,+12V DC	Without Heatsink
PA-18G-40G-1.2-HS	Power Amplifier,18-40GHz, Gain:35dB,Psat:1.2W,+12V DC	With Heatsink



Typical Performance Data:

Input VSWR vs Frequency

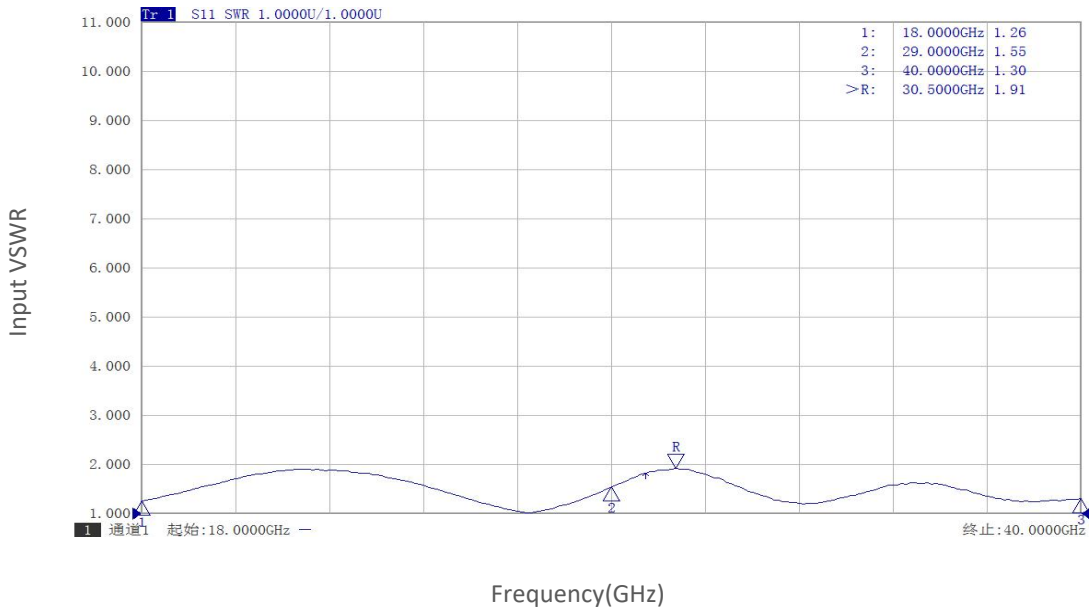

Small Signal Gain vs Frequency

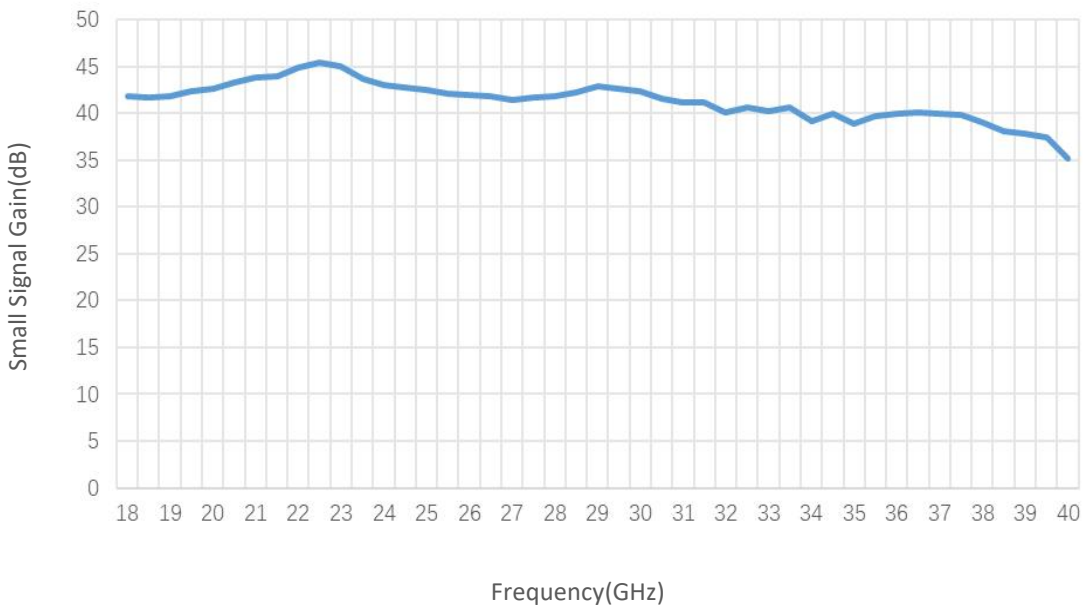

Note: Above data is for ref only, actual data may vary from unit to unit depending on operating environment and other factors like material lots etc.



Typical Performance Data:

PndB vs Frequency

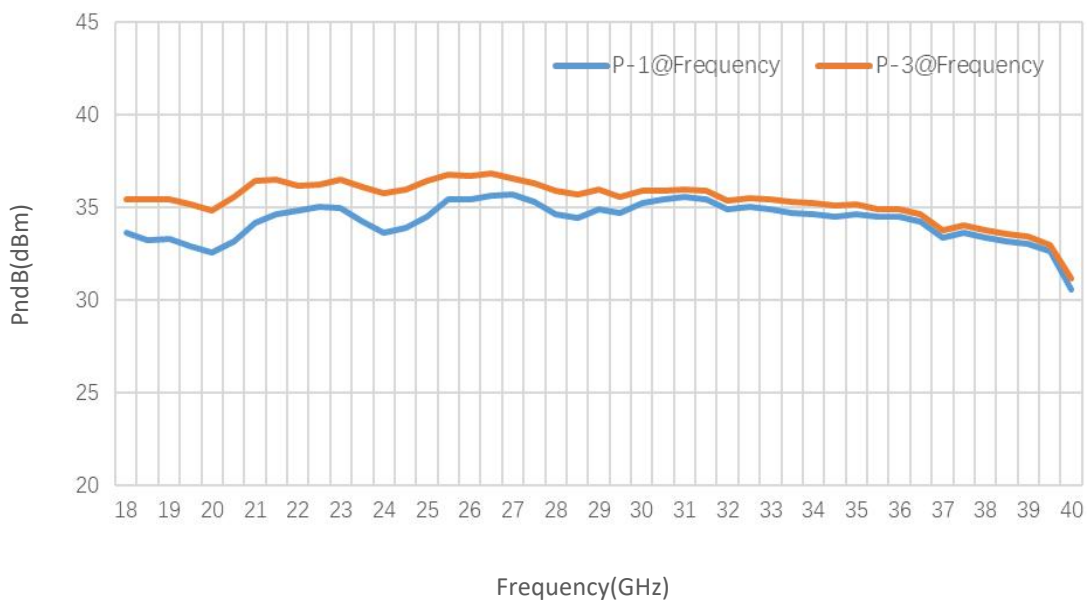

Pout@Pin

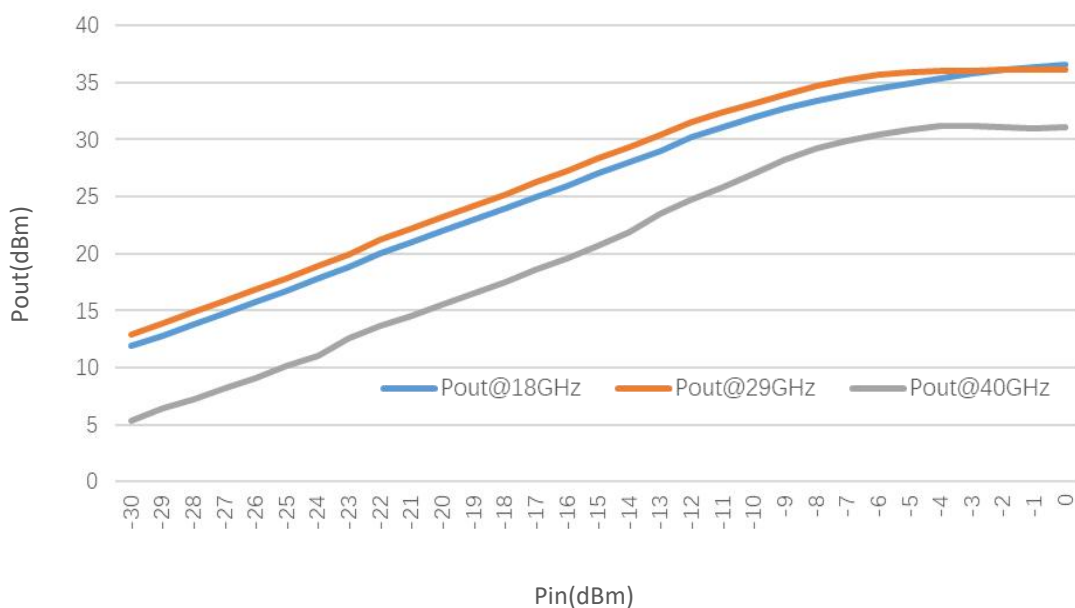

Note: Above data is for ref only, actual data may vary from unit to unit depending on operating environment and other factors like material lots etc.



Typical Performance Data:

Pout@Equal_Pin

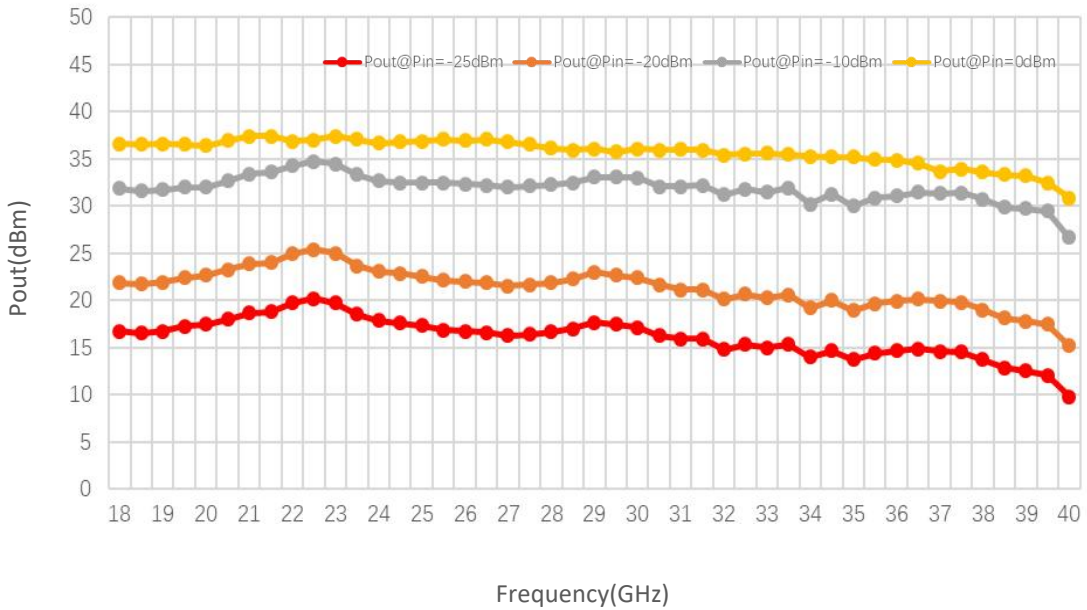

Spurious vs Frequency

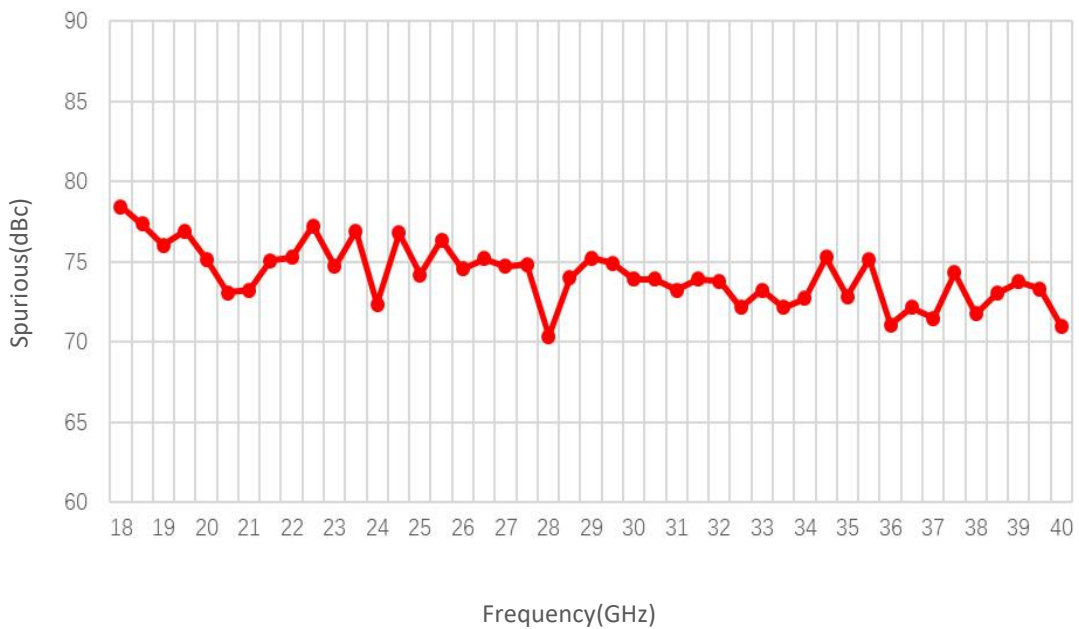

Note: Above data is for ref only, actual data may vary from unit to unit depending on operating environment and other factors like material lots etc.



Typical Performance Data:

Harmonic vs Frequency

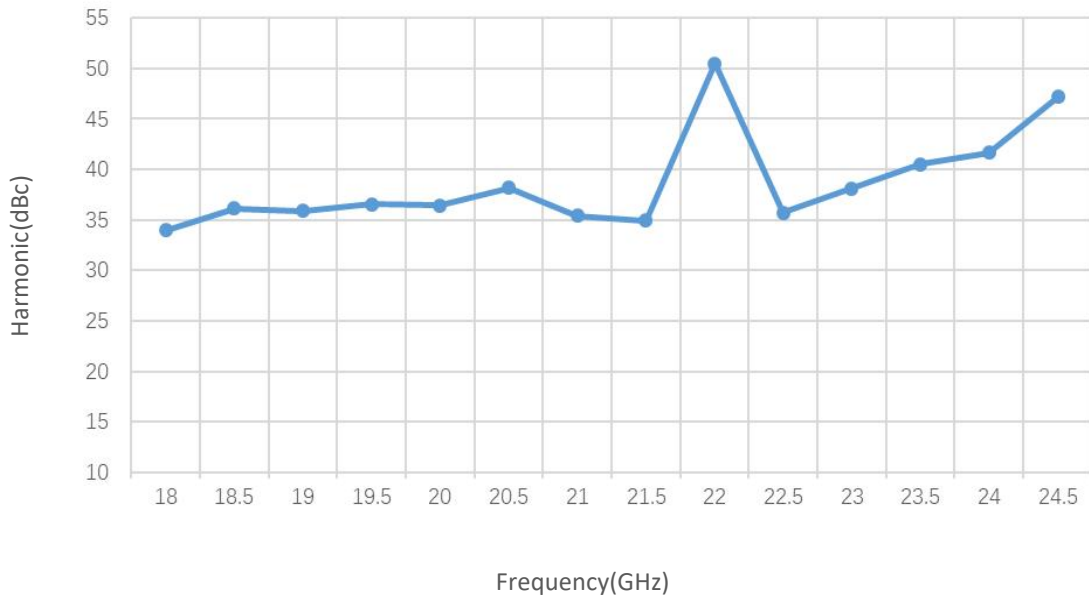

Note: Above data is for ref only, actual data may vary from unit to unit depending on operating environment and other factors like material lots etc.