



Power Amplifier

Model: PA-18G-40G-5-H

18-40GHz 5W CW

Ultrabroad frequency range, high performance and exceptional RF characteristics

Features:

- Frequency range: 18-40GHz
- High output power at saturation, 5W Typ.
- High gain, 40 dB Min.
- 50 Ohm Matched Input / Output.

Applications:

- Cellular
- PCN
- GSM
- ISM
- Lab Test

Product Overview:

The PA-18G-40G-5-H is a power amplifier with a minimum power gain of 40 dB and a nominal P_{sat} of 5W across the frequency range of 18 to 40 GHz. The DC power requirement for the amplifier is +20 VDC/90 W. The input and output port configuration offers coax adapter structure with 2.92mm female.



Electrical Specifications at 25°C:

Parameter	Min	Typ	Max	Units
Frequency range	18		40	GHz
Power Gain	40	45		dB
Output P1dB	30	32		dBm
Output Psat		37		dBm
Spurious			-50	dBc
Input VSWR		2		:1
DC Voltage		+20		V DC
Power Consumption			90	W
Impedance		50		Ohms

Mechanical Specifications:

Parameter	Value	Notes
Operating Temperature*	-40°C to +60°C	
Non-operating Temperature*	-50°C to +70°C	
Relative humidity	95	%
RF Input/Output Connector	2.92mm Female/2.92mm Female	
DC Bias	Feedthru capacitors	
Altitude	10,000	feet
Shock / Vibration(MIL-STD-810F)	25g rms (15 degree 2KHz) endurance, 1 hour per axis	
Shock(non operating)	20G for 11msc half sin wave,3 axis both directions	
Dimensions W x H x D	60*60*11(Without heatsink) 188*125*146(With heatsink)	mm
Weight	≤200	g

*Note: For a wider temperature range, please consult the manufacturer.

Absolute Maximum Ratings:

Parameter	Value
Supply Bias Voltage	+22 V
RF Input Power	+5 dBm
ESD sensitivity (HBm)	Class 0, passed 150V



Outline Drawing:

Unit:mm

PA-18G-40G-5-H-HS

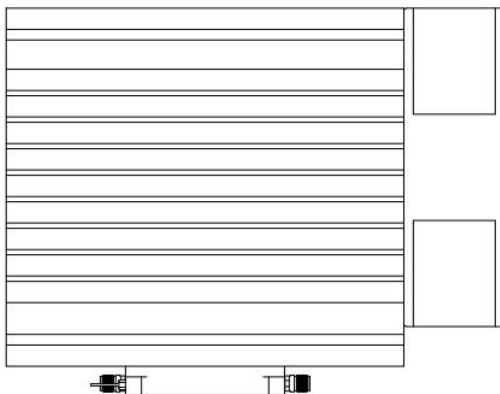
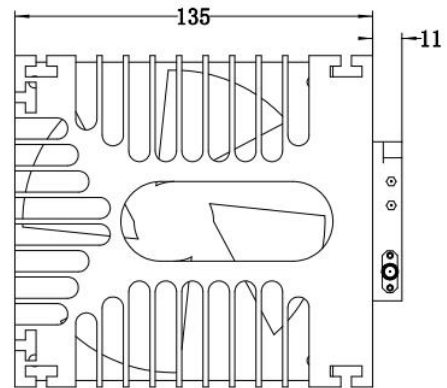
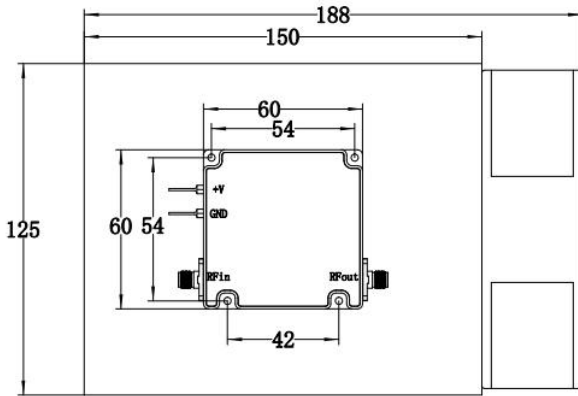

Ordering Information:

Base Number	Description	Optional
PA-18G-40G-5-H	Power Amplifier, 18-40GHz, Gain:40dB,Psat:5W,+20V DC	Without Heatsink
PA-18G-40G-5-H-HS	Power Amplifier, 18-40GHz, Gain:40dB,Psat:5W,+20V DC	With Heatsink



Typical Performance Data:

Input VSWR vs Frequency

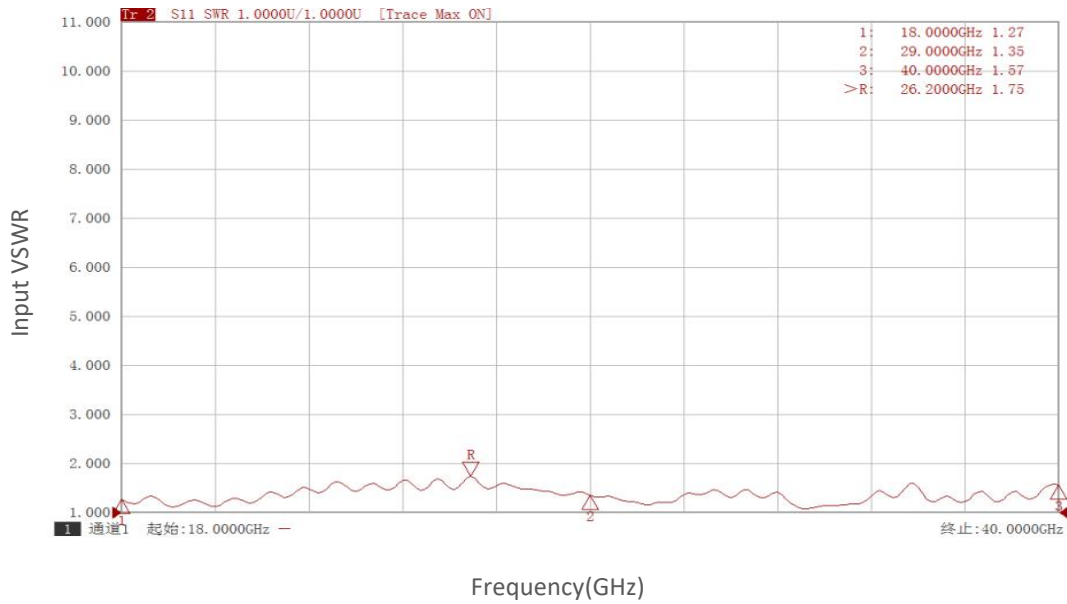

Small Signal Gain vs Frequency

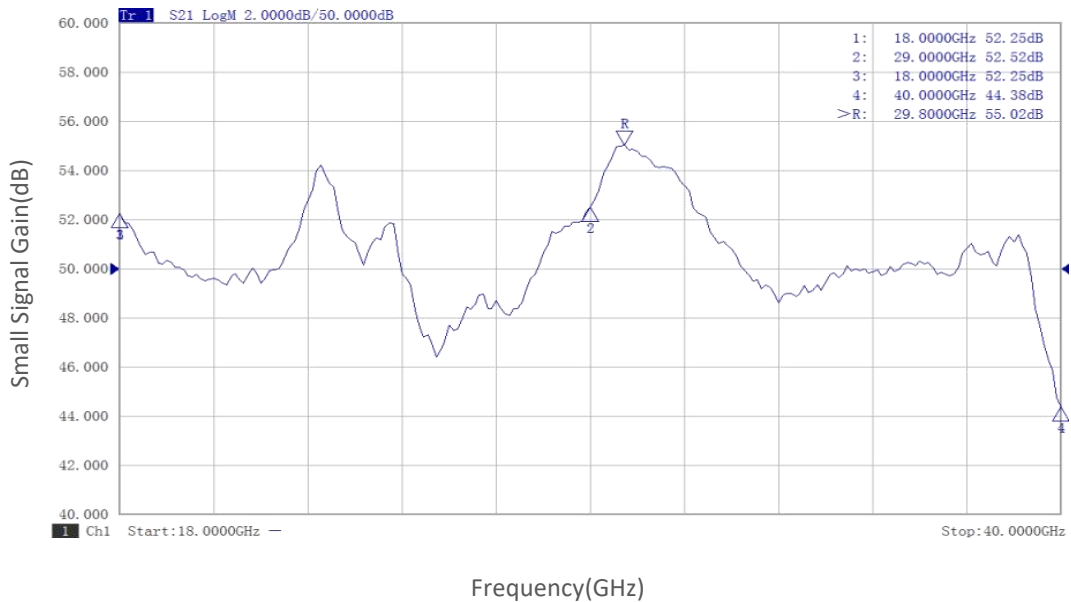

Note: Above data is for ref only, actual data may vary from unit to unit depending on operating environment and other factors like material lots etc.



Typical Performance Data:

P1dB vs Frequency

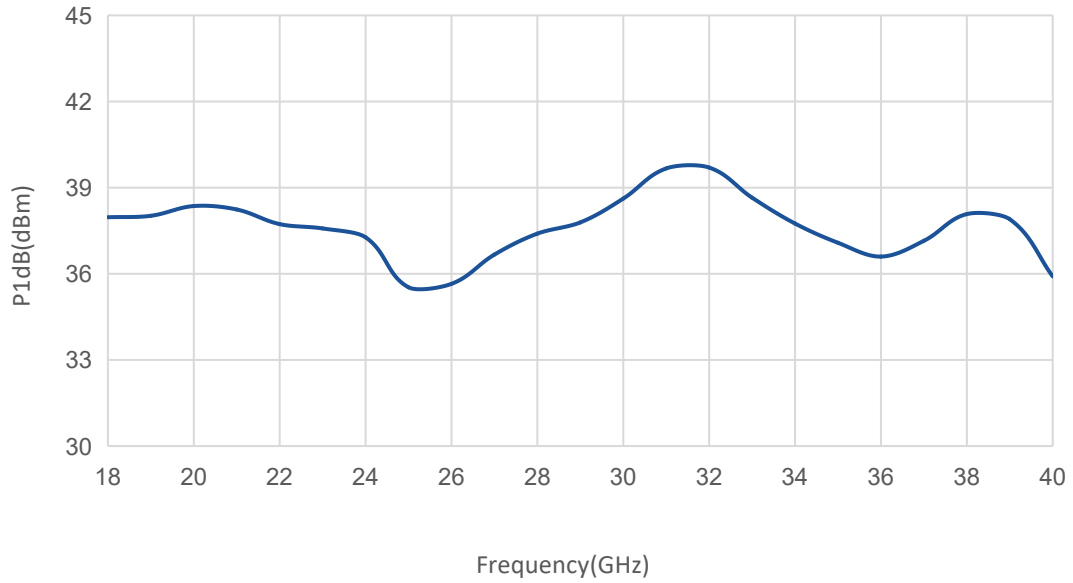

Pout@Pin

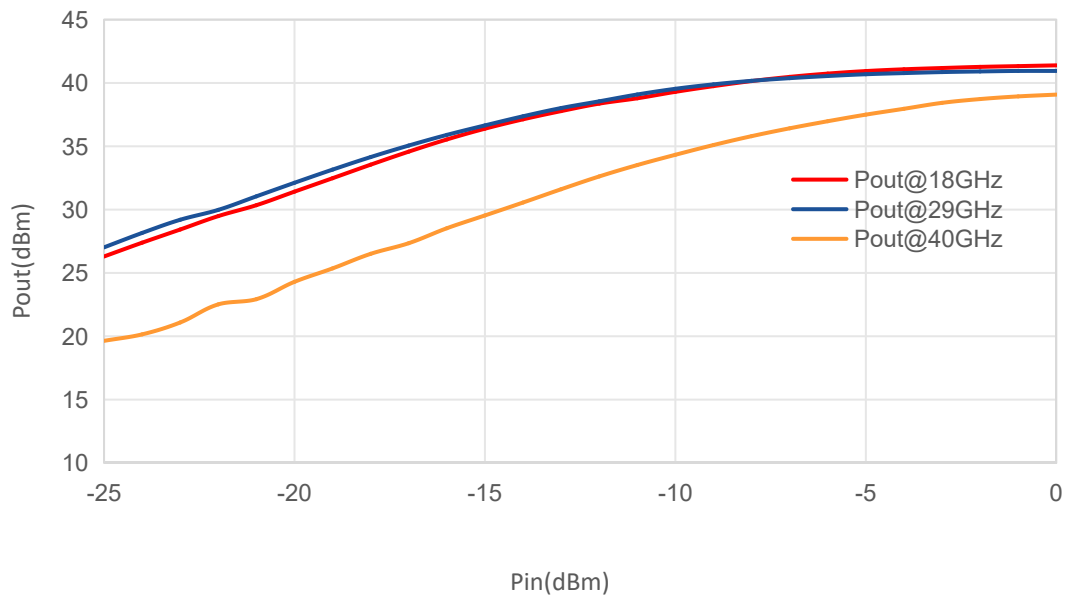

Note: Above data is for ref only, actual data may vary from unit to unit depending on operating environment and other factors like material lots etc.



Typical Performance Data:

Pout@Equal_Pin

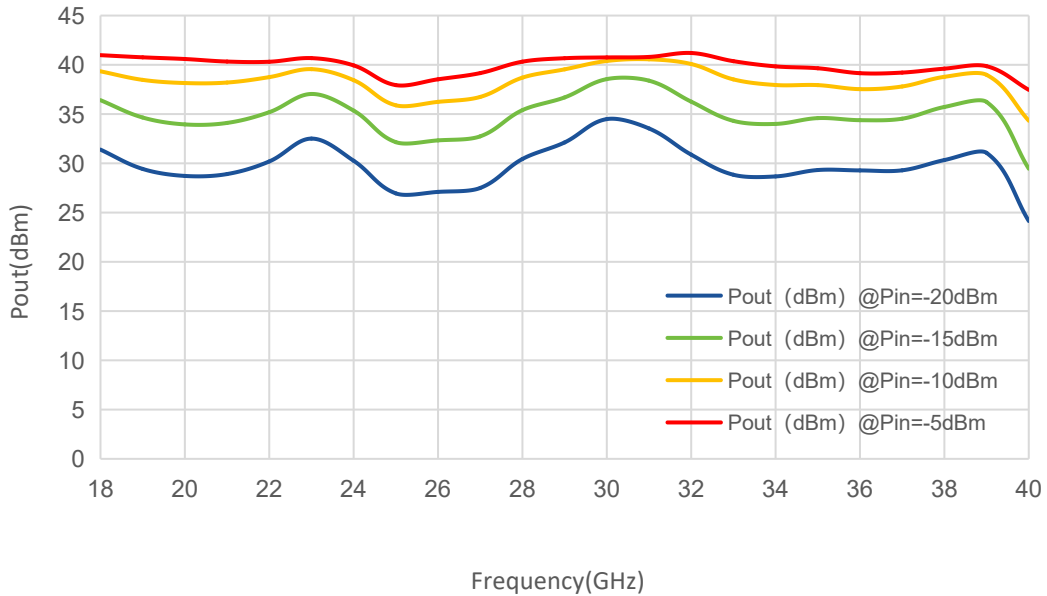

Spurious vs Frequency

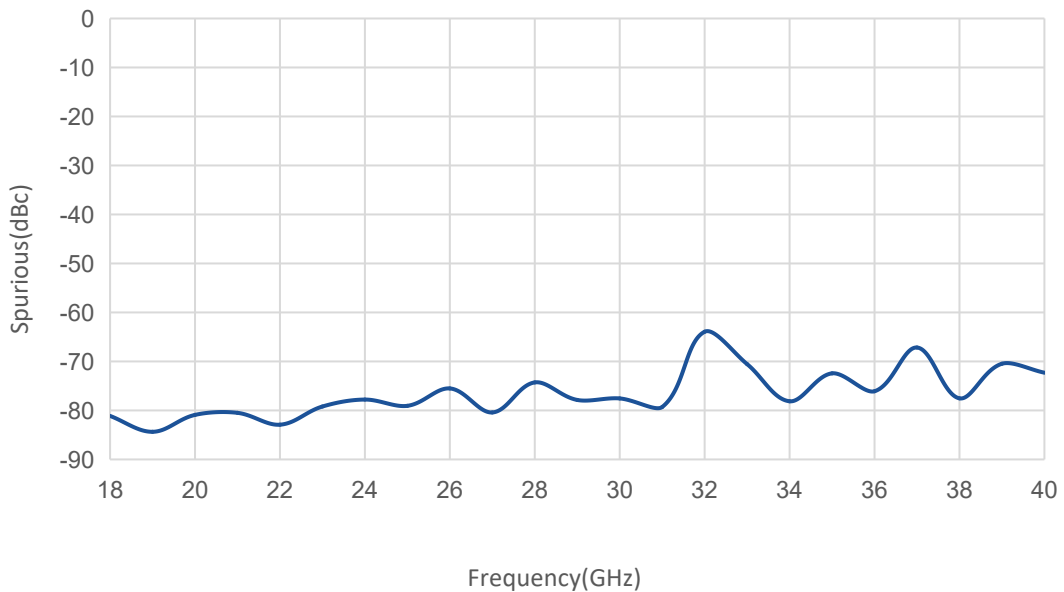

Note: Above data is for ref only, actual data may vary from unit to unit depending on operating environment and other factors like material lots etc.



Typical Performance Data:

Harmonic vs Frequency

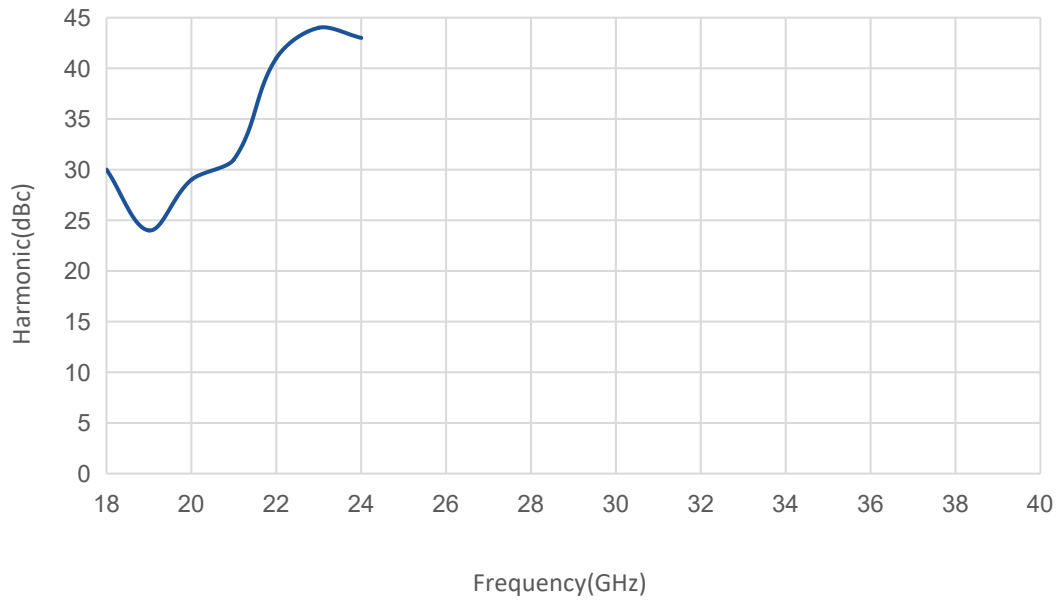

Note: Above data is for ref only, actual data may vary from unit to unit depending on operating environment and other factors like material lots etc.