



Frequency Conversion Component

Model: LNB-27G-31G5-50-IP67

27-31.5GHz 50dB, Gain

Low power consumption, high accuracy, fast response and high stability

Features:

- RF Frequency range: 27-31.5GHz
- IF Frequency range: 950-2450MHz
- Gain: 50dB
- External/Internal Reference Adaptive

Applications:

- Test Lab
- Instrumentations
- Auto Test Set

Product Overview:

The LNB-27G-31G5-50-IP67 is a frequency conversion component operating in the Ka-band. It features an integrated local oscillator, with input RF frequency of 27-31.5GHz and output IF frequency of 950~2450 MHz. Providing a conversion gain of 50 dB, it also supports adaptive switching between internal and external references.



Electrical Specifications at 25°C:

Parameter		Min	Typ	Max	Units
RF Input Frequency	@LO=26.05GHz	27		28.5	GHz
	@LO=27.05GHz	28		29.5	
	@LO=28.05GHz	29		30.5	
	@LO=29.05GHz	30		31.5	
IF Output Frequency		950		2450	MHz
Gain		50			dB
Gain Control Range			31.5		dB
Gain Control Step			0.5		dB
Gain Flatness				±2	dB
Noise Figure				3	dB
Image Rejection		40			dBc
Spurious@IF out				-60	dBc
Group Delay@100MHz BW				±2	ns
Output P1dB		15			dBm
Phase Noise	@1KHz			-80	dBc/Hz
	@10KHz			-85	
	@100KHz			-95	
	@1MHz			-100	
LO Reference Mode		External/Internal Reference Adaptive; External reference with fallback to Internal Refence			
External LO Reference Level (Sine wave, 100MHz)		5			dBm
Output Reference Clock @Output Power≥10dBm				100	MHz
VSWR				2	:1
DC Supply Voltage			12		V DC



Mechanical Specifications:

Parameter	Value	Notes
Operating Temperature	-30°C to +65°C	
RF Input/Output Connector	WR28/N Female	
Remote Control Connector	M8 Female, 4 pin (Pin1 = NC; Pin2 = A pos+ RS485; Pin3 = B neg- RS485; Pin4 = Common GND)	1、 LO Frequency Setting 2、 Digital Attenuator Setting 3、 Internal/External Reference Status Query 4、 PLL Lock Status Monitoring 5、 DC Power Supply Status Monitoring
Communication Connector	RS485	
DC supply Interface	SMA Female	+12 VDC
Reference Output Reference Interface	SMA Female	100MHz
External Reference Input Interface	SMA Female	100MHz
Ingress Protection Grade	IP-67	
Dimensions W x H x D	108.7*56*47.2	mm

Note: The PLL frequency and the Digital Attenuator attenuation will be done by writing a number in the relevant register as per the communication protocol.

Outline Drawing:

Unit:mm

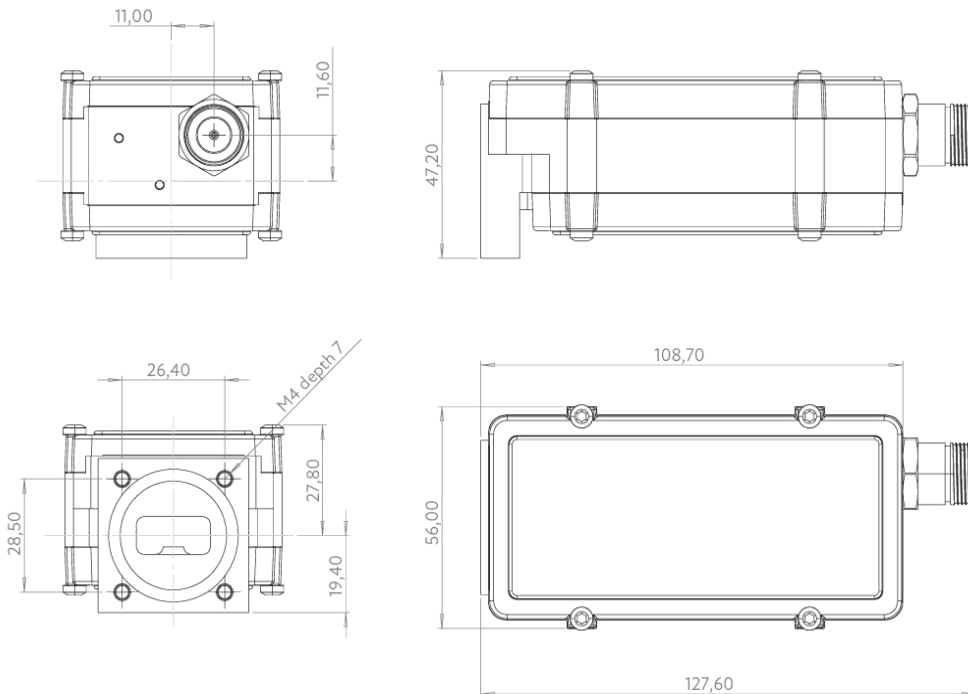

Notes:

The dimensions of the module is yet to be determined.



Functional Block Diagram:

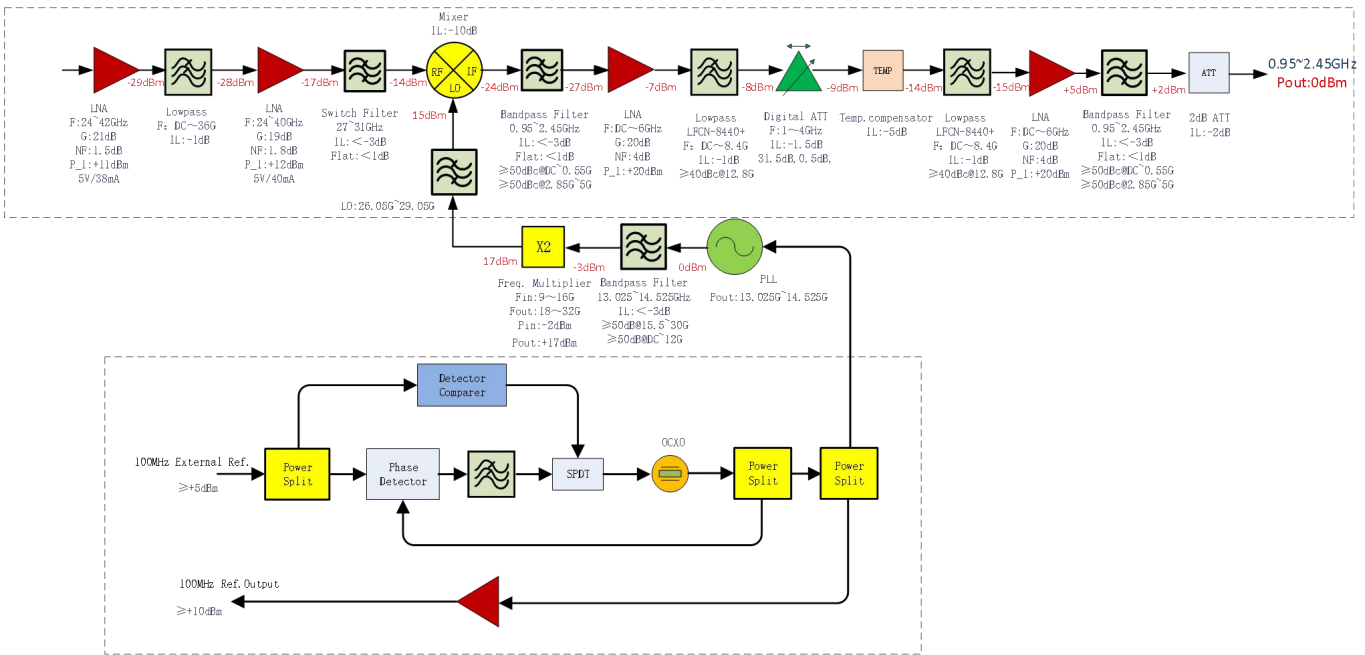

Ordering Information:

Base Number	Description
LNB-27G-31G5-50-IP67	Frequency Conversion Component, RF frequency; 27-31.5GHz, Gain: 50dB

Notes:

- 1、Dimensions and specifications may be changed without prior notice.
- 2、Standard Warranty: three years.



Typical Performance Data:

Input VSWR vs Frequency

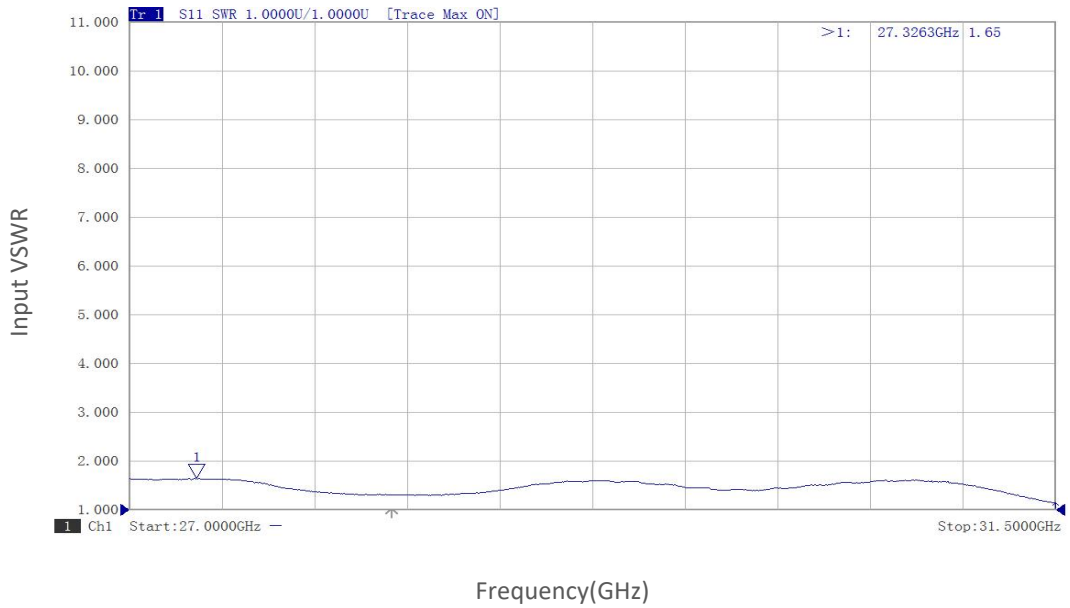

Output VSWR vs Frequency

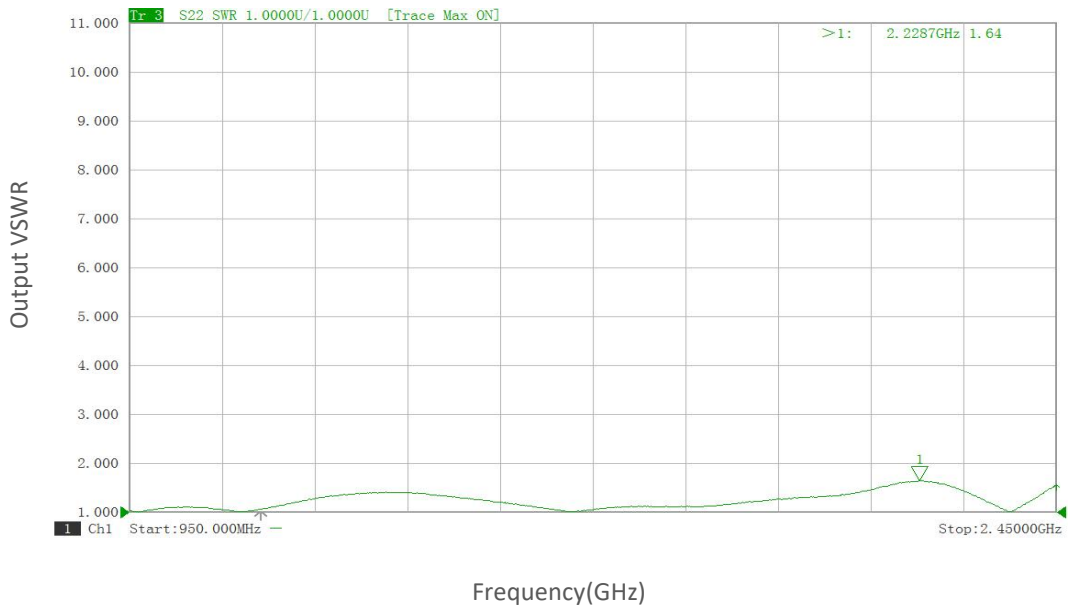

Note: Above data is for ref only, actual data may vary from unit to unit depending on operating environment and other factors like material lots etc.



Typical Performance Data:

Pout Flatness vs Frequency@RF Pin=-50dBm,27~28.5GHz

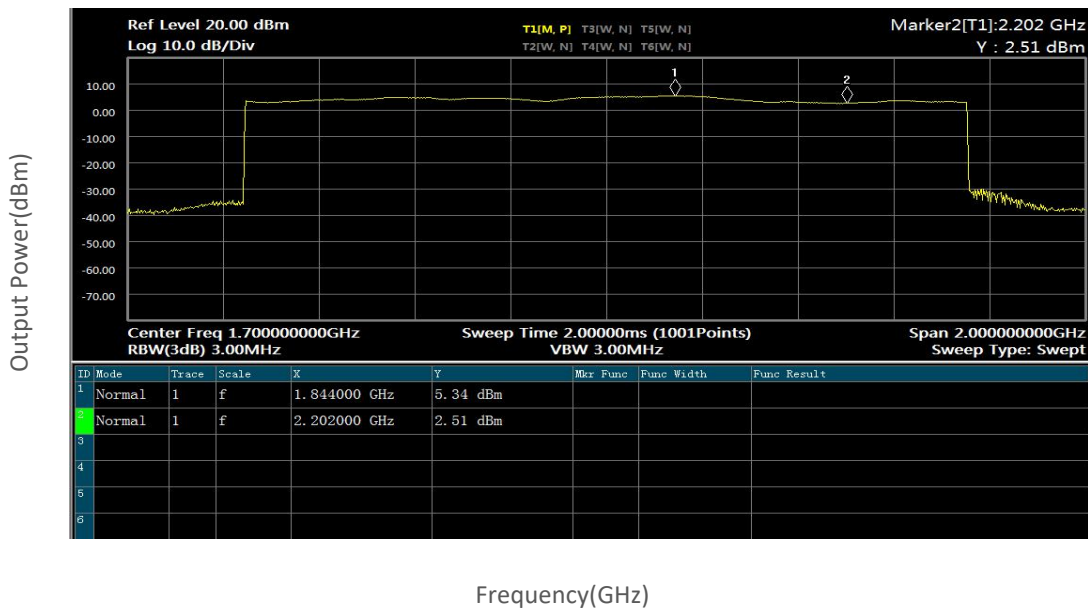

Pout Flatness vs Frequency@RF Pin=-50dBm,28~29.5GHz

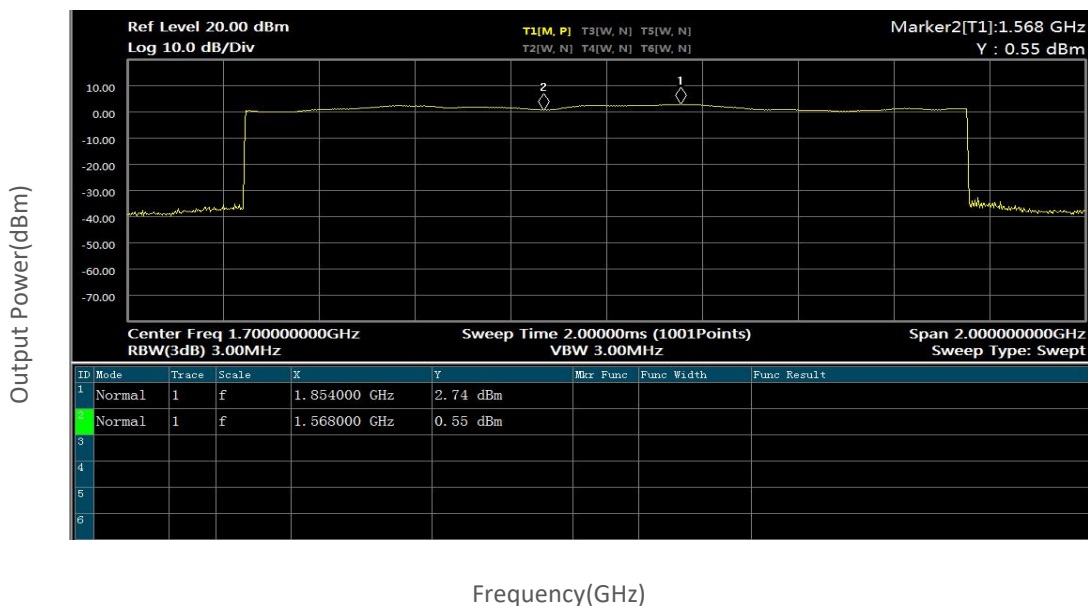

Note: Above data is for ref only, actual data may vary from unit to unit depending on operating environment and other factors like material lots etc.



Typical Performance Data:

Pout Flatness vs Frequency@RF Pin=-50dBm,29~30.5GHz

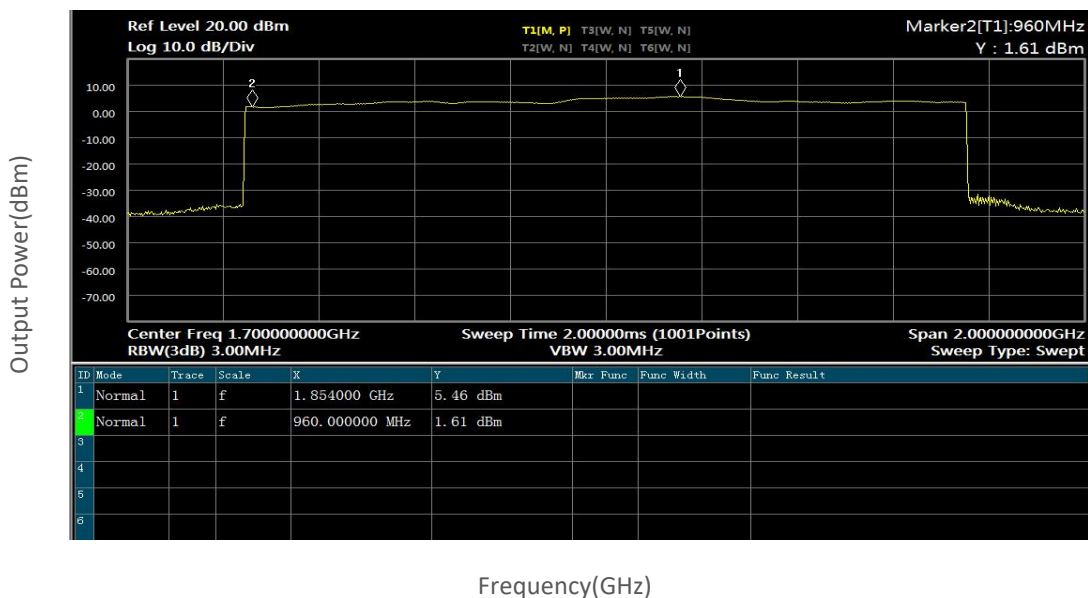

Pout Flatness vs Frequency@RF Pin=-50dBm,30~31.5GHz

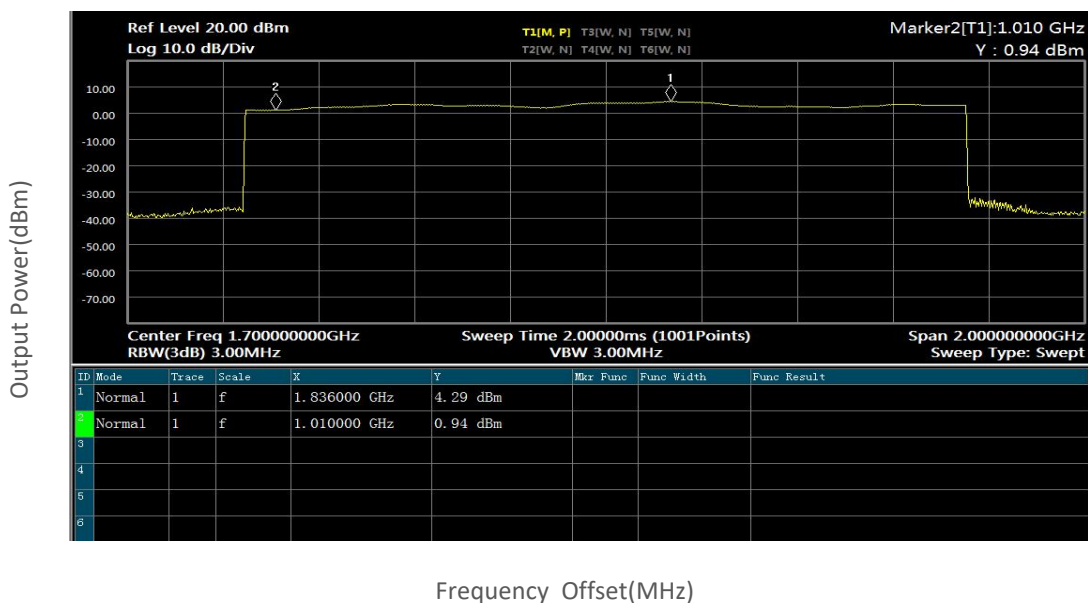

Note: Above data is for ref only, actual data may vary from unit to unit depending on operating environment and other factors like material lots etc.



Typical Performance Data:

Noise Figure vs Frequency

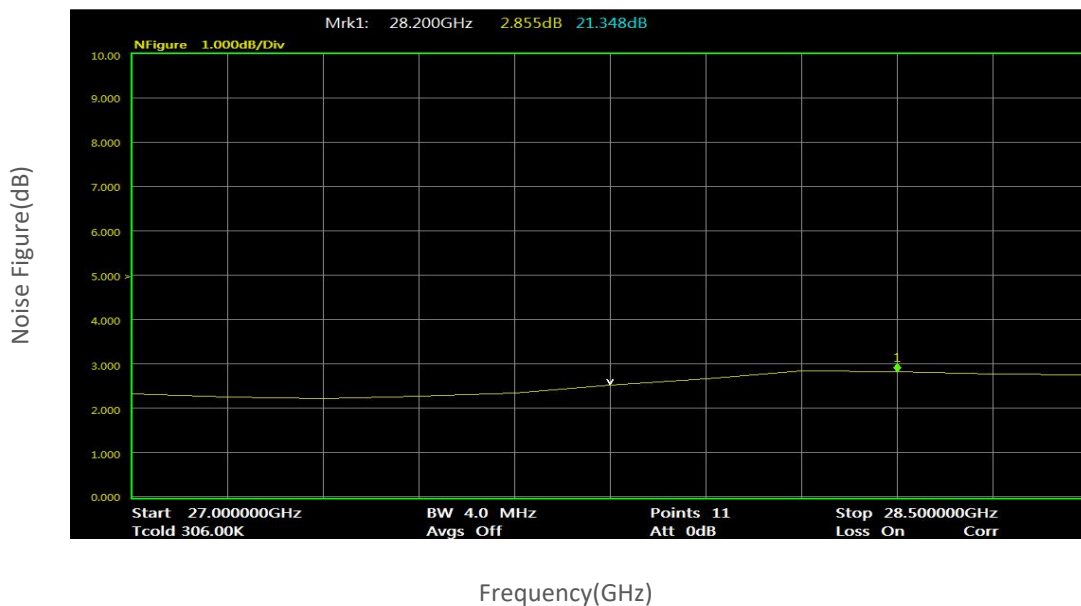

Noise Figure vs Frequency



Note: Above data is for ref only, actual data may vary from unit to unit depending on operating environment and other factors like material lots etc.



Typical Performance Data:

Noise Figure vs Frequency

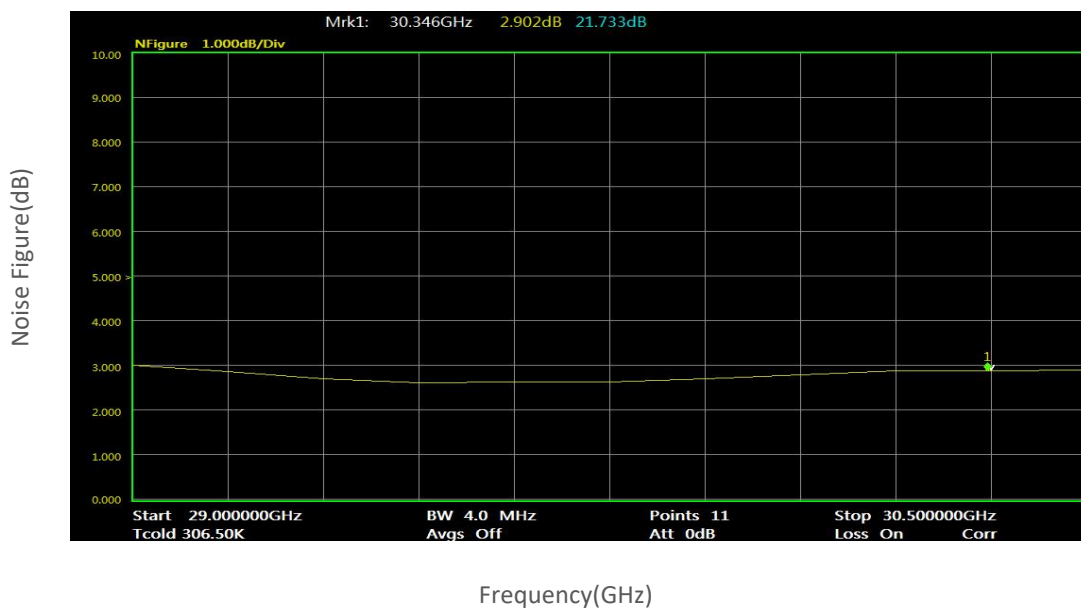

Noise Figure vs Frequency

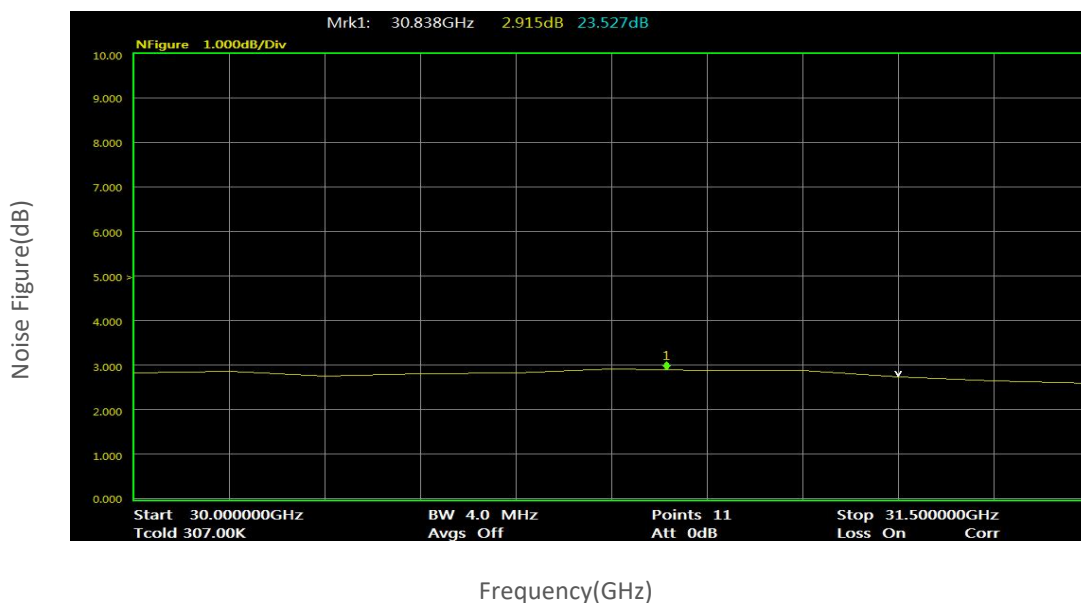

Note: Above data is for ref only, actual data may vary from unit to unit depending on operating environment and other factors like material lots etc.



Typical Performance Data:

Phase Noise @950MHz

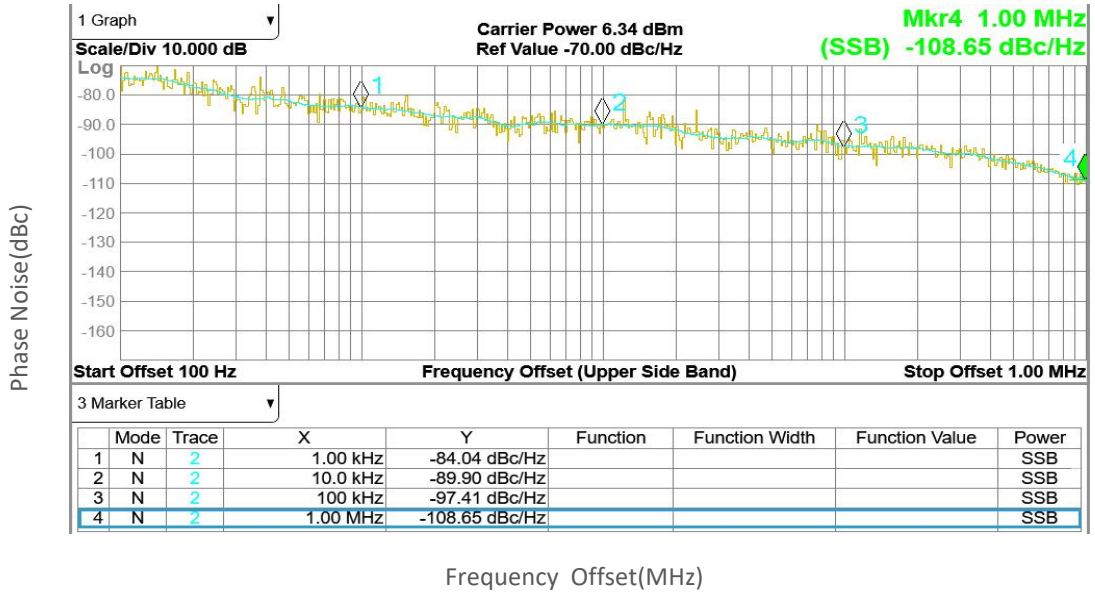

Phase Noise @1700MHz

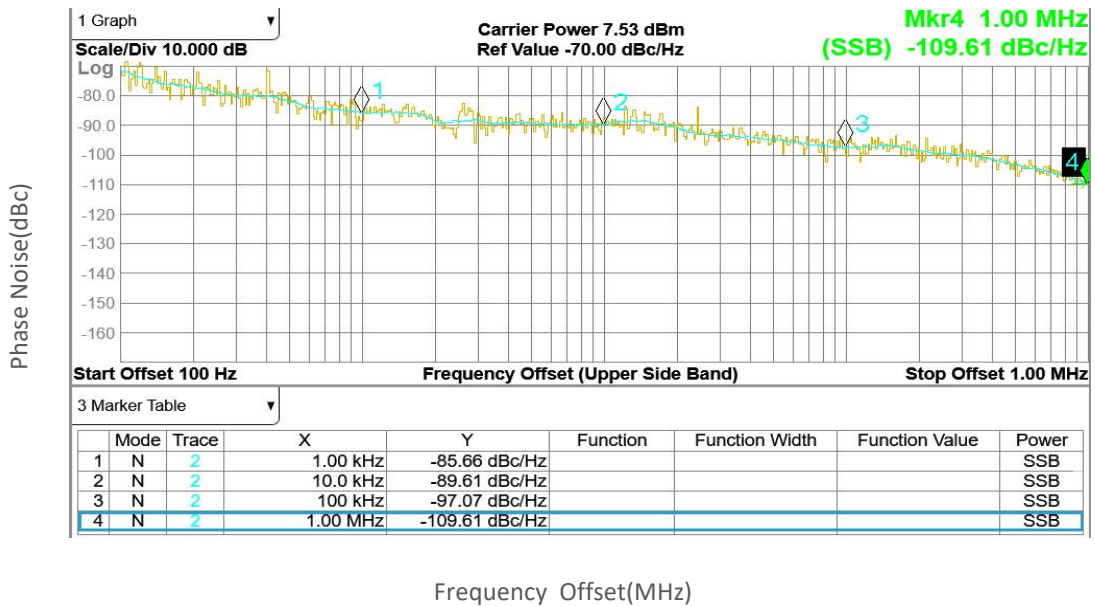

Note: Above data is for ref only, actual data may vary from unit to unit depending on operating environment and other factors like material lots etc.



Typical Performance Data:

Phase Noise @2450MHz

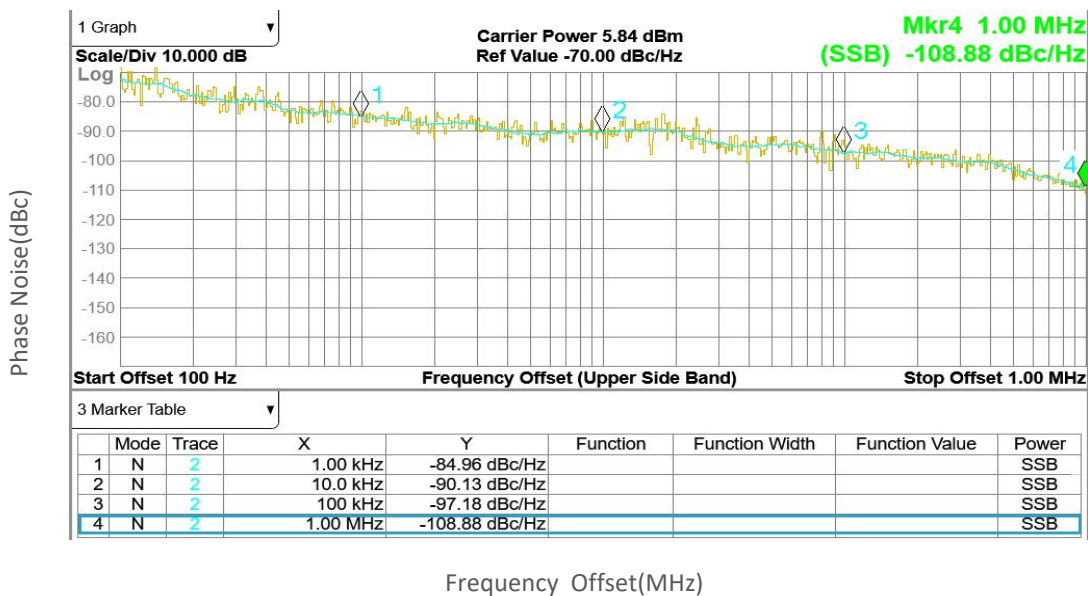

Near-end Spurious@1700MHz

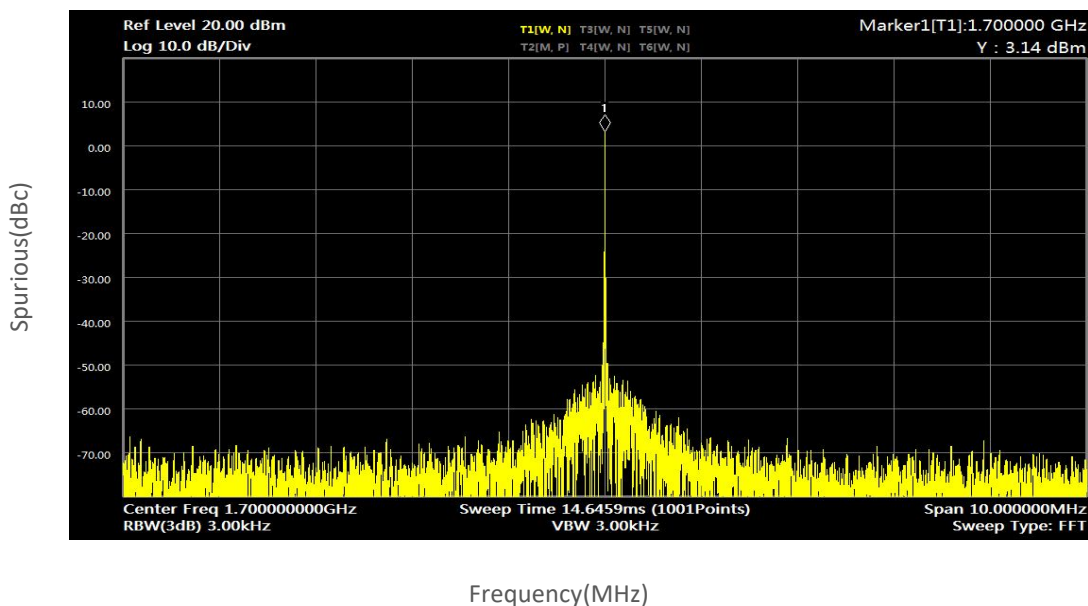

Note: Above data is for ref only, actual data may vary from unit to unit depending on operating environment and other factors like material lots etc.



Typical Performance Data:

Far-end Spurious vs Frequency

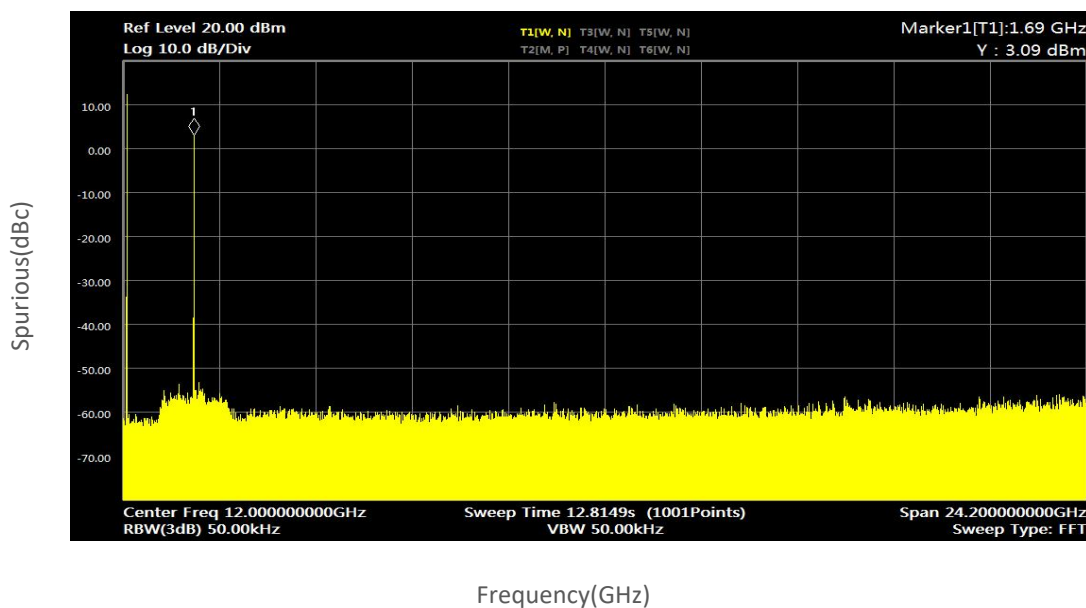

RF Pin:-50dBm@24.35GHz
LO Frequency=26.05GHz

Image Rejection@14.5GHz

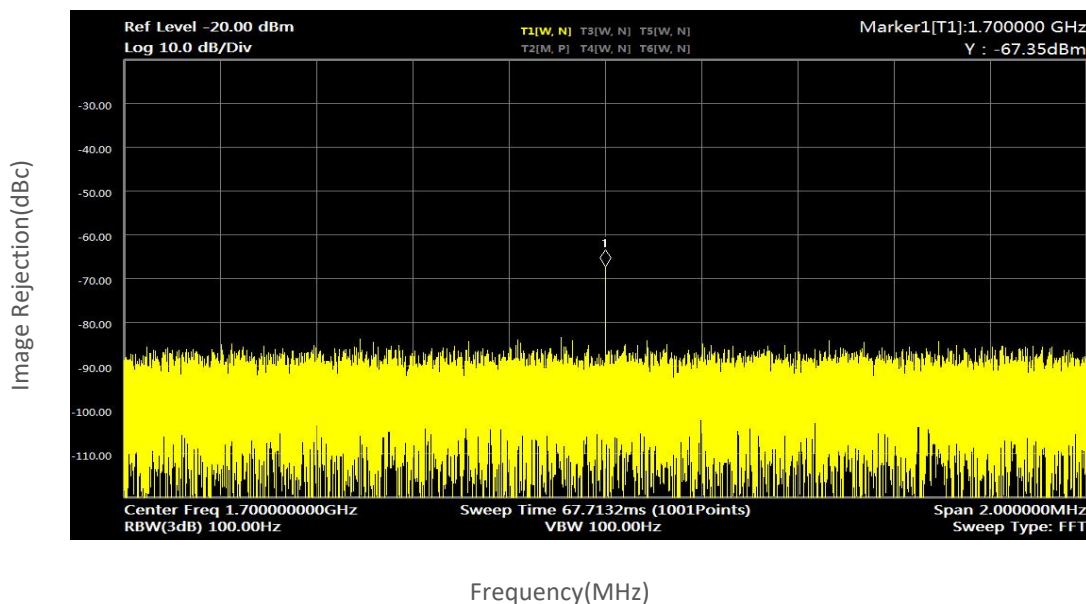

Note: Above data is for ref only, actual data may vary from unit to unit depending on operating environment and other factors like material lots etc.



Typical Performance Data:

Output Power@Output Reference Clock

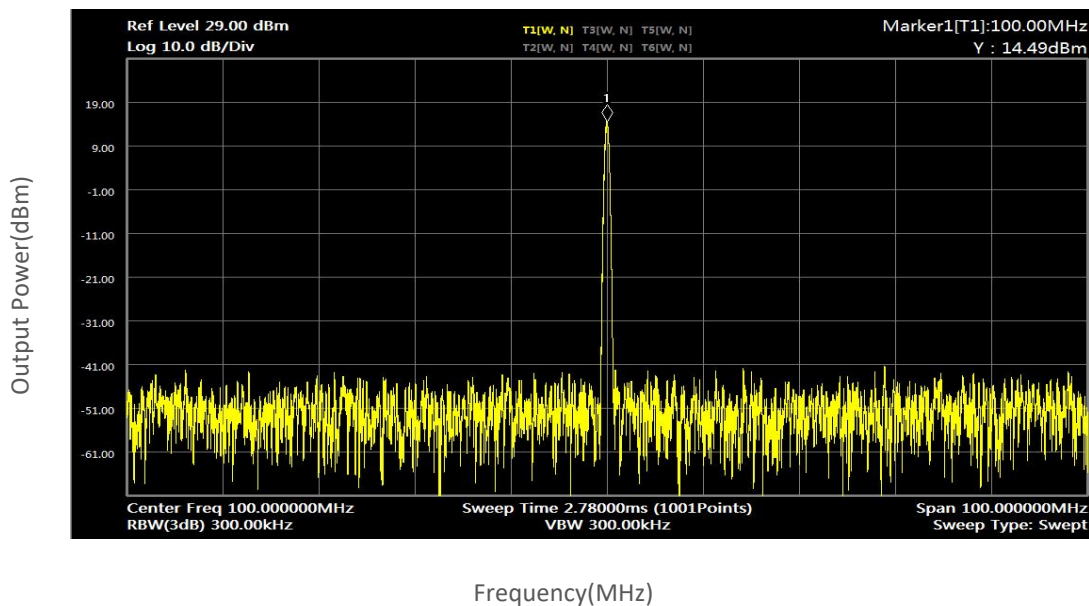

Note: Above data is for ref only, actual data may vary from unit to unit depending on operating environment and other factors like material lots etc.