



High Power Amplifier

Model:RPA-1G-6G-500

1-6GHz 500W CW

Ultrabroad frequency range, high performance and exceptional RF characteristics

Features:

- Frequency range: 1-6GHz
- High output power at saturation, 57dBm Min
- High gain, 57dB Min
- Operates from AC line power: 380V

Applications:

- Laboratory test instrument
- RF Power stress test
- EMI and antenna testing
- Reliability testing

Product Overview:

The RPA-1G-6G-500 is a high power, rack mount amplifier with a self-contained AC power supply which can be used for a wide variety of laboratory testing applications. This rugged amplifier is capable of amplifying signals up to 500W output power over its entire operating bandwidth of 1 to 6GHz. The control functions RPA-1G-6G-500 possesses include the on/off of the power supply and output power can be controlled by the automatic ALC system. Built-in safety features include fans alarms and automatic shut down mechanism to prevent damage in the event of excessive internal temperatures. The amplifier's output stage is further protected in the event of a fault condition, allowing high power operation for up to 5 minutes into an open or short load (refer to the maximum input power specifications). And it has built-in protection functions included over TEM, over voltage, under voltage, over current and over VSWR protection. It can also be remotely controlled via RS422 or Ethernet.



Electrical Specifications at 25°C:

Parameter	Symbol	Min	Typ	Max	Units
Frequency range	BW	1-6			GHz
Power Gain	GP	57			dB
Gain flatness	Δ GL		± 3		dB
Gain adjust Range	Δ GR		30		dB
Gain adjust Step	Δ GS		0.5		dB
Output Psat	Psat	57			dBm
Output P1dB	P1dB		52		dBm
Spurious	Spur			-60	dBc
Harmonics	HAM		-15	-10	dBc
Input VSWR	VSWRin			2.0	:1
AC Voltage	Vac		380		V AC
Impedance	I/O-IMP	50			Ohms

Mechanical Specifications:

Parameter	Value	Notes
Operating Temperature*	-20 to +40	°C
Non-operating Temperature*	-30 to +50	°C
Relative humidity	95	%
RF Input/Output Connector	N Female/L29 Female	
Digital Monitor & Control	RS422;Ethernet	
Cooling system	Built in Cooling system,forced air cooling	
Altitude	10,000	feet
Shock / Vibration(MIL-STD-810F)	25g rms (15 degree 2KHz) endurance, 1 hour per axis	
Shock(non operating)	20G for 11msc half sin wave,3 axis both directions	
Dimensions W x H x D	12U	mm
Weight	≤ 150	Kg

*Note: For a wider temperature range, please consult the manufacturer.



Absolute Maximum Ratings:

Parameter	Value
RF Input Power	+5 dBm
ESD sensitivity (HBm)	Class 0, passed 150V

Outline Drawing:

Unit:mm

RPA-1G-6G-500

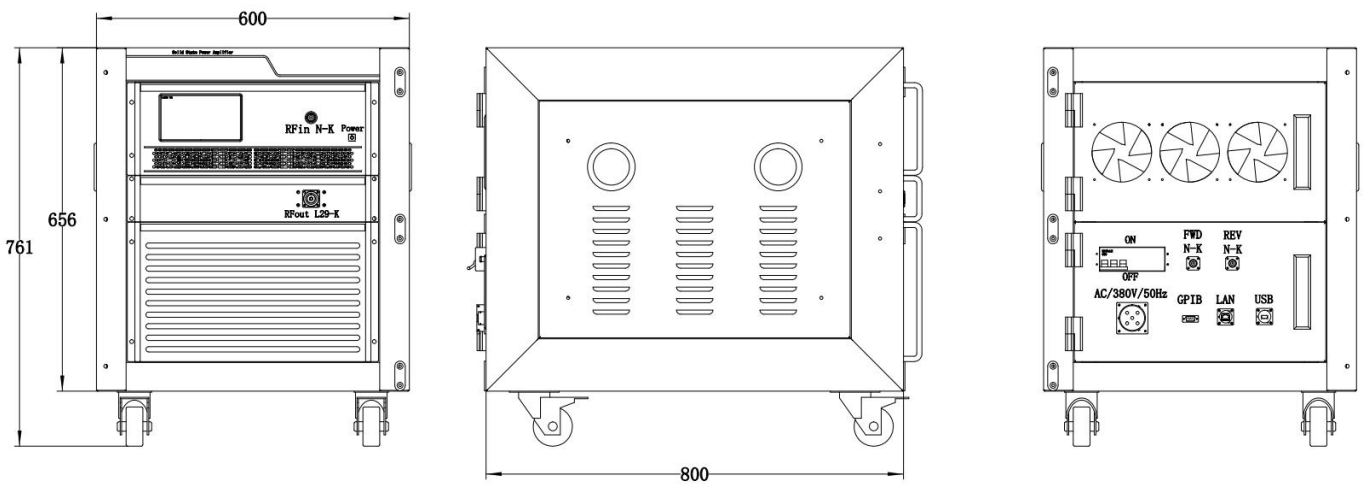

Optional items:

Number	Parameter
1	LCD display touchscreen
2	Ingress protection grad
3	Customized operating temperature range
4	Built in Cooling system(air or liquid)
5	Types of RF,coupling and monitor&control interfaces

Outline Drawing:

Base Number	Description	Optional
RPA-1G-6G-500	High Power Amplifier, 1-6GHz, 500W CW, Built in air or liquid cooling, without LCD and IP grad.	Basic version
RPA-1G-6G-500-M	High Power Amplifier, 1-6GHz, 500W CW, Built in air or liquid cooling, with LCD.	Add LCD display touchscreen
RPA-1G-6G-500-IPxx	High Power Amplifier, 1-6GHz, 500W CW, Built in air or liquid cooling, with LCD and IP grad.	Add Ingress protection grad